

Owner's Manual

Care and Operation

INSTALLER: Leave this manual with party responsible for use and operation.
OWNER: Retain this manual for future reference.

NOTICE: DO NOT discard this manual!



Model:
ODLANAIG-51

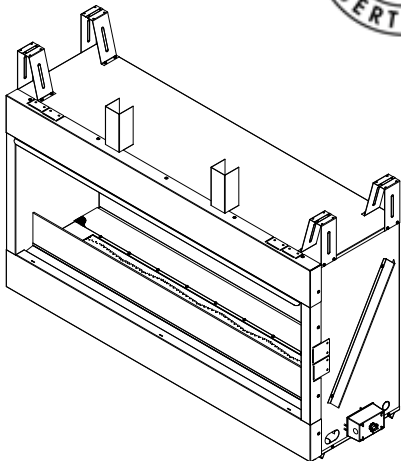

DANGER:

If you smell gas:

1. Shut off gas to the appliance.
2. Extinguish any open flame.
3. If odor continues, keep away from the appliance and immediately call your gas supplier or fire department.

WARNING: For outdoor use only.

WARNING:

Do not store or use gasoline or other flammable vapors and liquids in the vicinity of this or any other appliance
An LP-cylinder not connected for use Shall not be stored in the vicinity of this or any other appliance

WARNING! Risk Of Fire!

Do not install glass doors on this fireplace.
Glass doors could cause overheating of adjacent structures.

WARNING:

Improper installation, adjustment, alteration, service or maintenance can cause injury or property damage. Read the installation, operating and maintenance instructions thoroughly before installing or servicing this equipment.

DANGER



Carbon Monoxide Hazard

This appliance can produce carbon monoxide which has no odor.

Using it in an enclosed space can kill you.

Never use this appliance in an enclosed space such as a camper, tent, car or home

▲Safety Alert Key:

- **DANGER!** Indicates a hazardous situation which, if not avoided will result in death or serious injury.
- **WARNING!** Indicates a hazardous situation which, if not avoided could result in death or serious injury.
- **CAUTION!** Indicates a hazardous situation which, if not avoided, could result in minor or moderate injury.
- **NOTICE:** Used to address practices not related to personal injury.

Table of Contents

1 Welcome

- A. Congratulations3
- B. Limited Warranty.....4

2 Product Specific Information

- A. Appliance Certification6
- B. BTU Specifications6

3 Important Safety and Operating Information

- A. Appliance Safety7
- B. General Operating Parts.....8
- C. Fuel Specifications8
- D. Before Lighting Appliance.....8
- E. Lighting Instructions (IPI).....9
- F. Appliance Break-in10
- G. Wall Control.....10
- H. LED Control.....10

4 Maintenance and Service

- A. Maintenance – Frequency and Tasks11
- B. Maintenance Tasks – Homeowner11
- C. Maintenance Tasks – Qualified Service Technician12

5 Frequently Asked Question and Troubleshooting

- A. Frequently Asked Questions.....13
- B. Troubleshooting13
- C. Troubleshooting – Screen/LEDs/Control Panel15
- D. Accessing the LEDs16

6 Reference Materials

- A. Accessories17
- B. Service Parts18
- C. Contact Information24

1 Welcome

A. Congratulations

Congratulations on selecting an Outdoor Lifestyles gas fireplace, an elegant and clean alternative to wood burning fireplaces. The Outdoor Lifestyles gas fireplace you have selected is designed to provide the utmost in safety, reliability, and efficiency.

As the owner of a new fireplace, you'll want to read and carefully follow all of the instructions contained in this owner's manual. Pay special attention to all cautions and warnings.

This owner's manual should be retained for future reference. We suggest that you keep it with your other important documents and product manuals. The information contained in this owner's manual, unless noted otherwise, applies to all models and gas control systems.

Your new Outdoor Lifestyles gas fireplace will give you years of durable use and trouble-free enjoyment. Welcome to the Outdoor Lifestyles family of fireplace products!

Local Dealer Information

Dealer: Fill in your name, address, phone number and email information in the space provided.

Appliance Information:

Brand: _____

Serial Number: _____

Dealer Name: _____

Address: _____

Phone Number: _____

Email: _____

Model Name: _____

Date Installed: _____

Listing Label Information/Location

The model information regarding your specific fireplace can be found on the rating plate usually located in the control area of the fireplace.

Outdoor Lifestyles by
outdoor lifestyles
 by hearth & home technologies®
 149 Cleveland Drive, Paris, KY 40361

20308572

ANSI Z21.97-2014
 CSA 2.41-2014

Outdoor Decorative
 Gas Appliances



This appliance must be installed in accordance with local codes, if any; if not, follow ANSI Z223.1 in the USA Installation codes.

Outdoor Gas Appliance – for outdoor use only. Not for use with solid fuel. Do not connect to a remote gas supply.

Type of Gas: **NATURAL GAS**

Model: **ODLANAIG-51**

Serial: POD22(incremental)

MFG Date: 2016/01/04 (incremental)



Type of Gas Model Name

Minimum Permissible Gas Supply for Purposes of Input Adjustment.

	<i>Natural Gas</i>	<i>Propane Gas</i>
Minimum Pressure.....	5.0in. w.c.....	11in. w.c.....
Maximum Pressure.....	10.5in. w.c.....	13in. w.c.....
Max Input BTU/H.....	55,000BTU.....	53,000BTU.....
Orifice Size:.....	#32 (2).....	#52 (2).....

Total Electrical Requirements: 110-120Vac, 60Hz., less than 12 Amperes

Gas Information

B. Limited Warranty

Outdoor Lifestyles by Hearth & Home Technologies™

Limited Warranty

Hearth & Home Technologies (“HHT”) extends the following warranty for all Outdoor Lifestyles by HHT™ brand products (“Products”) that are purchased from an HHT authorized dealer.

WARRANTY COVERAGE:

HHT warrants to the original owner of the Product at the site of installation, and to any transferee taking ownership of the Product at the site of installation within one year following the date of original purchase, that the Product will be free from defects in materials and workmanship at the time of manufacture. After installation, if covered components manufactured by HHT are found to be defective in materials or workmanship during the applicable warranty period, HHT will, at its option, repair or replace the covered components. This warranty is subject to conditions, exclusions and limitations as described below.

WARRANTY PERIOD:

The warranty period runs for one year, beginning on the earlier of: (i) the date of invoice for the Product; (ii) in the case of new home construction, the date of first occupancy of the residence or six months after the date of sale of the Product by an HHT authorized dealer, whichever occurs first; or (iii) the date 24 months following the date of Product shipment from HHT, regardless of the invoice or occupancy date.

WARRANTY CONDITIONS:

- This warranty only covers Products that are purchased through an HHT authorized dealer or distributor. A list of HHT authorized dealers is available on the HHT branded websites.
- This warranty is only valid while the Product remains at the site of original installation.
- Contact your installing dealer for warranty service. If the installing dealer is unable to provide necessary parts, contact the nearest HHT authorized dealer or supplier. Additional service fees may apply if you are seeking warranty service from a dealer other than the dealer from whom you originally purchased the Product.
- Check with your dealer in advance for any costs to you when arranging a warranty call. Travel and shipping charges for parts are not covered by this warranty.

WARRANTY EXCLUSIONS:

This warranty does not cover the following:

- Changes in surface finishes as a result of normal use. As a heating appliance, some changes in color of interior and exterior surface finishes may occur; this is not a flaw and not covered under warranty.
- Damage to printed, plated, or enameled surfaces caused by fingerprints, accidents, misuse, scratches, melted items, or other external sources and residues left on surfaces from the use of abrasive cleaners or polishes.
- Repair or replacement of parts that are subject to normal wear and tear during the warranty period. These parts include: paint, firebricks, grates, flame guides and the discoloration of glass.
- Minor expansion, contraction, or movement of certain parts causing noise. These conditions are normal and complaints related to this noise are not covered by this warranty.

B. Limited Warranty (continued)

- Damages resulting from: (1) failure to install, operate, or maintain the Product in accordance with the installation instructions, operating instructions, and listing agent identification label furnished with the Product; (2) failure to install the Product in accordance with local building codes; (3) shipping or improper handling; (4) improper operation, abuse, misuse, continued operation with damaged, corroded or failed components, accident, or incorrectly performed repairs; (5) inadequate ventilation, negative pressure or environmental conditions, including, without limitation: hail, snow, ice, fallen branches, flooding, water damage and fading of color; (6) use of fuels other than those specified in the operating instructions; (7) installation or use of components not supplied with the Product or any other components not expressly authorized and approved by HHT; (8) modification of the Product not expressly authorized and approved by HHT in writing; and/or (9) interruptions or fluctuations of electrical power supply to the Product.
- Non-HHT venting components, hearth components or other accessories used in conjunction with the Product.
- Any part of a pre-existing fireplace system in which an insert or a decorative gas appliance is installed.
- The Product's capability to heat the desired space. Information is provided to assist the consumer and the dealer in selecting the proper appliance for the application. Consideration must be given to the Product's location and configuration and environmental conditions.

This warranty is void if:

- The Product has been over-fired or operated in atmospheres contaminated by chlorine, fluorine, or other damaging chemicals. Over-firing can be identified by, but not limited to, warped plates or tubes, rust colored cast iron, bubbling, cracking and discoloration of steel or enamel finishes and cracking or spalling of refractory or cementitious materials.
- The Product is subjected to prolonged periods of dampness, condensation, ice or snow.
- There is any damage to the Product or other components due to water or weather damage which is the result of, but not limited to, improper chimney or venting installation.

LIMITATIONS OF LIABILITY:

Repair or replacement in accordance with the provisions of this warranty will be the owner's exclusive remedy for and will constitute HHT's sole obligation under this warranty, under any other warranty (express or implied), or in contract, tort or otherwise; provided, however, that if HHT is unable to provide repair or replacement in an expedient and cost effective manner, HHT may discharge all such obligations by refunding the purchase price of the Product. No employee, agent, dealer, or other person is authorized to give any warranty on behalf of HHT. TO THE EXTENT ALLOWED BY LAW, HHT MAKES NO OTHER WARRANTY, EXPRESSED OR IMPLIED, INCLUDING ANY WARRANTY OF MERCHANTABILITY OR FITNESS FOR A PARTICULAR PURPOSE. HHT WILL NOT BE LIABLE FOR ANY CONSEQUENTIAL OR INCIDENTAL DAMAGES ARISING OUT OF DEFECTS IN OR USE OF THE PRODUCTS. Some states do not allow exclusions or limitation of incidental or consequential damages, so these limitations may not apply to you. This warranty gives you specific rights; you also may have other rights, which vary from state to state. The duration of any implied warranty is limited to the duration of the warranty period specified herein.

2 Product Specific Information

A. Appliance Certification

Model: ODLANAIG-51
Laboratory: Canadian Standards Association (CSA)
Type: Outdoor Decorative Gas Appliances
Standard: ANSI Z221.97-2014, CSA 2.41-2014

This product is listed to ANSI standards for “Outdoor decorative Gas appliances” and “Gas Fired Appliances for Use at High Altitudes”.

Notice: *This installation must conform with local codes. In the absence of local codes you must comply with the National Fuel Gas Code, ANSI Z223.1- latest edition in the U.S.A. and the CAN/CGA B149 Installation codes in Canada.*

*When an appliance is for connection to a fixed piping system, the installation must conform with local codes, or in the absence of local codes with the **National Fuel Gas Code, ANSI Z223.1/NFPA 54, or International Fuel Gas Code.***

B. BTU Specifications

Model	Gas Type	Max Input BTU	Orifice Size
ODLANAIG-51	Natural	55,000	(2) #32
	Propane	53,000	(2) # 52

Installation and service of this appliance should be performed by qualified personnel. Hearth & Home Technologies recommends HHT Factory Trained or NFI certified professionals

myhht
FACTORY
training



3 Important Safety and Operating Information

A. Appliance Safety

WARNING! DO NOT operate fireplace before reading and understanding operating instructions. Failure to operate fireplace according to operating instructions could cause fire or injury.

WARNING

HOT SCREENS WILL CAUSE BURNS.



DO NOT TOUCH FIREPLACE UNTIL COOLED.

NEVER ALLOW CHILDREN TO TOUCH FIREPLACE.

- Keep children away.
- CAREFULLY SUPERVISE children in same room as fireplace.
- Alert children and adults to hazards of high temperatures.

High temperatures may ignite clothing or other flammable materials.

- Clothing, furniture, draperies and other flammable materials must not be placed on or near the appliance.

Young children should be carefully supervised when they are in the same room as the appliance. Toddlers, young children and others may be susceptible to accidental contact burns.

- A physical barrier is recommended if there are at risk individuals in the house.
- To restrict access to an appliance, install an adjustable safety gate to keep toddlers, young children and other at risk individuals out of the room and away from hot surfaces.
- Install wall switch out of reach of children.
- Never leave a child alone near a hot fireplace, whether operating or cooling down.
- Teach children to NEVER touch the fireplace.
- Consider not using the fireplace when children will be present.

Contact your dealer for more information, or visit: www.hpba.org/safety-information.

To prevent unintended operation when not using your fireplace for an extended period of time (winter months, vacations, trips, etc.):

- Turn off wall controls.
- Turn off gas shutoff valve.
- Turn off GFCI protected circuit breaker.

Screen

This appliance has an optional screen cover. This cover is designed to protect the inside of the appliance from trash or other debris buildup when the appliance is not in use (sticks, leaves, etc.)

The appliance may be operated with the optional screen installed.

Clear Space

WARNING! DO NOT place combustible objects in front of the fireplace. High temperatures could start a fire. See Figure 3.1 Avoid placing candles and other heat-sensitive objects on mantel or hearth. Heat could damage these objects.

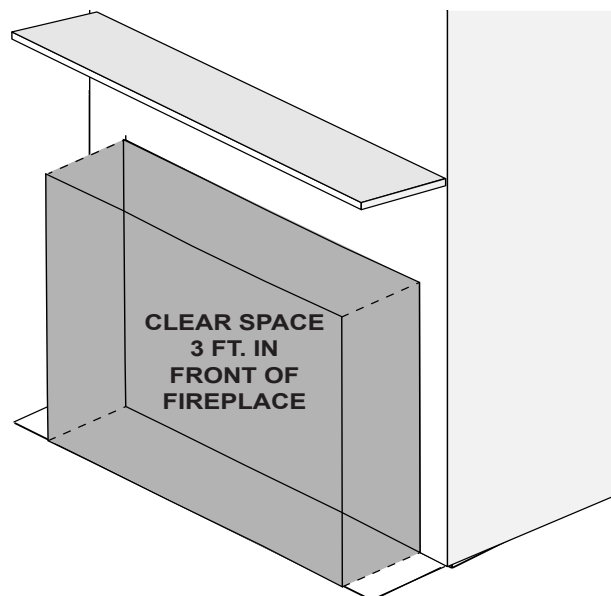

Figure 3.1. Clear Space Requirement

Over Firing

The appliance is considered to be over firing if the flames are contacting the top of the firebox. Call a qualified service technician to service the appliance.

B. General Operating Parts

Figure 3.2 references the general operating parts of the appliance and the section of this manual in which they are discussed.

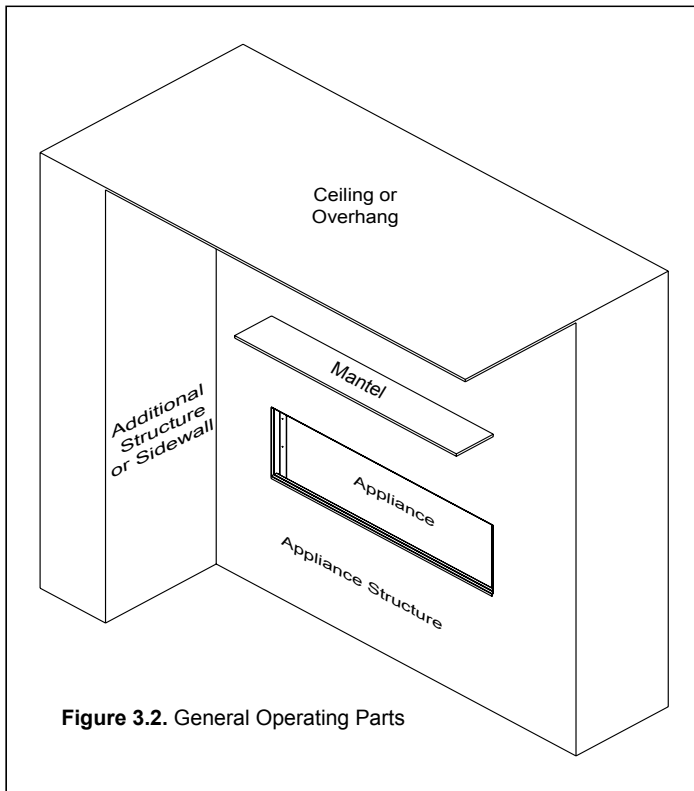

C. Fuel Specifications

WARNING! RISK OF FIRE OR EXPLOSION!
Appliance must be set up for compatible gas type!

- This appliance is designed to operate on either natural gas or propane. Make sure the appliance is compatible with gas type selected for installation site.
- Conversions must be made by a qualified service technician using Hearth & Home Technologies specified and approved parts.

D. Before Lighting Appliance

Before operating this fireplace for the first time, **have a qualified service technician:**

- Verify all shipping materials have been removed from inside and/or underneath the firebox.
- Review proper placement of media.
- Check the wiring.
- Ensure that there are no gas leaks.
- Remove all stainless steel coating material.

E. Lighting Instructions (IPI)

Lighting instructions may be found on the inside of the control compartment.

FOR YOUR SAFETY READ BEFORE LIGHTING

WARNING: If you do not follow these instructions exactly, a fire or explosion may result causing property damage, personal injury or loss of life.

- A.** This appliance is equipped with an intermittent pilot ignition (IPI) device which automatically lights the burner. **DO NOT** try to light the burner by hand.
- B. BEFORE LIGHTING,** smell all around the appliance area for gas. Be sure to smell next to the floor because some gas is heavier than air and will settle on the floor.
- WHAT TO DO IF YOU SMELL GAS**
- **DO NOT** try to light any appliance.
 - **DO NOT** touch any electric switch; do not use any phone in your building.
- C. DO NOT** use this appliance if any part has been under water. Immediately call a qualified service technician to inspect the appliance and to replace any part of the control system and any gas control which has been under water.
- Immediately call your gas supplier from a neighbor's phone. Follow the gas supplier's instructions.
 - If you cannot reach your gas supplier, call the fire department.

WARNING:

DO NOT CONNECT LINE VOLTAGE (110/120 VAC OR 220/240 VAC) TO THE CONTROL VALVE.

Improper installation, adjustment, alteration, service or maintenance can cause injury or property damage. Refer to the owner's information manual provided with this appliance.

This appliance needs fresh air for safe operation and must be installed so there are provisions for adequate combustion and ventilation air.

If not installed, operated, and maintained in accordance with the manufacturer's instructions, this product could expose you to substances in fuel or fuel combustion which are known to the State of California to cause cancer, birth defects, or other reproductive harm.

Keep burner and control compartment clean. See installation and operating instructions accompanying appliance.

For additional information on operating your
Hearth & Home Technologies fireplace, please refer to www.fireplaces.com.

CAUTION:

Hot while in operation. **DO NOT** touch. Keep children, clothing, furniture, gas-line and other liquids having flammable vapors away.

NOT FOR USE WITH SOLID FUEL

For use with natural gas and propane. A conversion kit, as supplied by the manufacturer, shall be used to convert this appliance to the alternate fuel.

For assistance or additional information, consult a qualified installer, service agency or the gas supplier.

LIGHTING INSTRUCTIONS (IPI)

1. This appliance is equipped with an ignition device which automatically lights the burner. **DO NOT** try to light the burner by hand.

**GAS
VALVE**

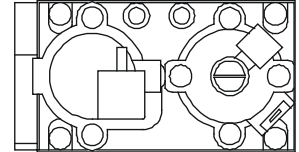

2. Wait five (5) minutes to clear out any gas. Then smell for gas, including near the floor. If you smell gas, STOP! Follow "B" in the Safety Information located on the left side of this label. If you do not smell gas, go to next step.
3. To light the burner:
Equipped with wall control: Press ON button.
4. If the appliance does not light after three tries, call your service technician or gas supplier.

TO TURN OFF GAS TO APPLIANCE

1. Equipped with wall control: Press OFF button.
2. Service technician should turn off electric power to the control when performing service.

Final inspection by _____

F. Appliance Break-in

Initial Break-in Procedure

When you light the appliance, you may notice that it produces heat which does have an associated odor or smell. This appliance should be run three to four hours on the initial start-up. Turn it off and let it cool completely.

WARNING! Risk of Fire or Burns! Provide adequate clearance for service access. Due to high temperatures, the appliance should be located out of traffic and away from furniture and draperies.

WARNING! DO NOT place combustible objects in front of the fireplace. High temperatures could start a fire.

G. Wall Control

Wall Control Operation

The Lanai series appliance comes standard with a rocker switch and two (2) button wall control panel. See Figure 3.3

On/Off – This switch toggles the On/Off function of the main burner

- On Position: Appliance will ignite main burner and run continuously (wall rocker switch).
- Off Position: Appliance main burner off

H. LED Control

• Multi-colored LED lights – These two (2) buttons turn LEDs ON (HI/MED/LO) and OFF function and cycle through the color selection.

1. **Color Fade** – This setting will cycle through the colors shown below at a normal rate.

2. **Color Fade Slow** – This setting will cycle through the colors shown below at a slower rate.

3. **Pause Color** – This setting will pause the slow color fade at any color in the color wheel.

4. **Solid Color Selection** – This setting will cycle through each color in order:

- Blue
- Violet
- Red
- Yellow
- Green
- Cyan
- White

CAUTION! Risk of Electric Shock! Avoid touching wires and electrical components in appliance control cavity.

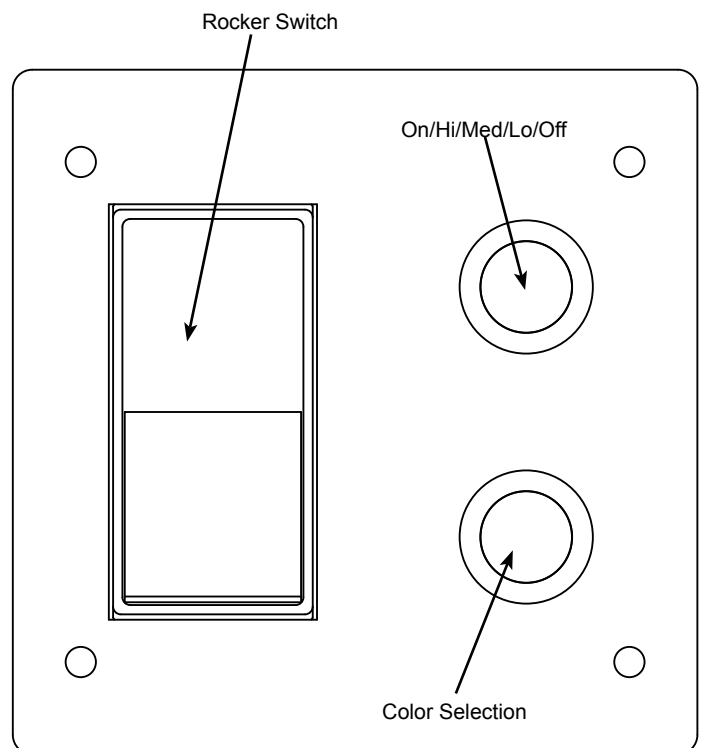

Figure 3.3. Wall Control Switch

4 Maintenance and Service

Any safety screen or guard removed for servicing must be replaced prior to operating the fireplace.

When properly maintained, your appliance will give you many years of trouble-free service. Contact your dealer to answer questions regarding proper operation, troubleshooting and service for your appliance. visit www.hearthnhome.com to locate a dealer. We recommend annual service by a qualified service technician.

A. Maintenance – Frequency and Tasks

Task:	Frequency:	To be completed by:
Optional Screen	Annually	Homeowner
Wall Control	Seasonally	
Burner ignition and operation	Annually	Qualified Service Technician

B. Maintenance Tasks – Homeowner

Installation and repair should be done by a qualified service technician only. The appliance should be inspected before use and at least annually by professional service person.

The following tasks may be performed annually by the homeowner. If you are uncomfortable performing any of the listed tasks, please call your dealer for a service appointment.

More frequent cleaning may be required due to excessive dirt, dust, leaves, etc. It is imperative that control compartments, burners and circulating air passageways of the appliance be kept clean. Any safety screen, guard or barrier removed for servicing the appliance must be replaced prior to operating the appliance.

CAUTION! Risk of Burns! The fireplace shall be turned off and cooled before servicing.

Optional Screen

Frequency: Annually

By: Homeowner

Tools needed: Protective gloves

- Assess condition of cover/screen and replace as necessary.

- Inspect for scratches, dents or other damage that can lead to rust when exposed to weather. Repair as necessary.
- Vacuum and dust surfaces.

Wall Control

Frequency: Seasonally

By: Homeowner

Tools needed: None

- Verify operation of controls
 - On/Off
 - LED lights

Cleaning the Media

Caution! Make sure the media is cool to the touch before removing media from the appliance

During shipment of the media, dust and debris can accumulate. It is recommended that the media be rinsed thoroughly with water to remove dust and small particles. An easy method to clean the media is to place the media into a pail and rinse thoroughly. Spread the media out over paper towels and allow the media to dry before installing them into the fireplace.

Cleaning the Appliance

Caution! Before cleaning make sure the unit is cool and the power to the unit is turned off.

Using a stainless steel cleaner. Apply to a terry cloth and wipe unit following the grain of the stainless. Do not spray cleaner directly into the unit. Use caution while cleaning the mesh as the edges are sharp and may tear the cleaning cloth. For cleaning the LED strips a terry cloth with clean water is all that is required.

C. Maintenance Tasks – Qualified Service Technician

The following tasks must be performed by a qualified service technician.

NOTICE: *Soot may accumulate on the pilot assembly and the area above the firebox opening. Periodic cleaning may be required.*

Burner Ignition and Operation

Frequency: Annually

By: Qualified Service Technician

Tools needed: Protective gloves, vacuum cleaner, whisk brook, flashlight, voltmeter, indexed drill set and a manometer.

- Check for smooth lighting and ignition carryover to all ports. Verify that there is no ignition delay.
- Inspect for lifting or other flame problems.
- Verify manifold and inlet pressures. Adjust regulator as required.
- Inspect pilot flame pattern and strength. Clean or replace orifice spud as necessary.
- Inspect pilot flame sensing rod for soot, corrosion and deterioration. Polish with fine steel wool or replace as required.
- Verify that there is not a short in flame sense circuit by checking continuity between pilot hood and flame sensing rod. Replace pilot as necessary.

5 Frequently Asked Question and Troubleshooting

A. Frequently Asked Questions

ISSUE	SOLUTION
Odor from fireplace	When first operated, this fireplace may release an odor for the first several hours. This is caused by the burning off of any oils remaining from manufacturing. Odor may also be released from finishing materials and adhesives used around the fireplace.
Metallic noise	Noise is caused by metal expanding and contracting as it heats up and cools down, similar to the sound produced by a furnace or heating duct. This noise does not affect the operation or longevity of the fireplace.
Wall above appliance feels hot to the touch	No action is necessary. This appliance ships with a non-combustible material. Specifications of the non-combustible material are listed in the Installer's Manual for this appliance.

Contact your dealer for additional information regarding operating and troubleshooting. Visit www.hearthnhome.com to locate a dealer

B. Troubleshooting

With proper installation, operation and maintenance your gas appliance will provide years of trouble-free service. If you do experience a problem, this troubleshooting guide will assist a qualified service technician in the diagnosis of a problem and the corrective action to be taken. This troubleshooting guide can only be used by a qualified service technician. Contact a dealer to arrange a service call by a qualified service technician.

IntelliFire™ Ignition System

SYMPTOM	POSSIBLE CAUSE	CORRECTIVE ACTION
Pilot Won't light. The ignition/module makes noise, but no spark.	Incorrect Wiring	Verify "S" wire (orange) for ignitor are connected to correct terminals on module and pilot assembly.
	Loose connections or electrical shorts in the wiring.	Verify no loose connections or electrical shorts in wiring from module to pilot assembly. Verify connections underneath pilot assembly are tight; also verify igniter and flame sense wires are not grounding out to metal chassis, pilot burner, pilot enclosure, mesh screen if present, or any other metal object.
	Ignitor gap is too large	Verify gap of igniter to right side of pilot hood. The gap should be approximately .17 in. or 1/8 in. (3 mm).
Pilot won't light. There is no noise or spark,	No power, transformer installed incorrectly.	Verify that transformer is installed and plugged into module. Check voltage of transformer at connection to module. Acceptable readings of a good transformer are between 3.2 and 2.8 volts AC.
	A shorted or loose connection in wiring configuration or wire harness.	Remove and reinstall the wiring harness that plugs into module. Verify there is a tight fit. Verify pilot assembly wiring to module. Remove and verify continuity of each wire in wiring harness. Replace any damaged components.
	Junction box Wiring	Verify that 110-120 VAC power is "ON" to junction box.
	Module not grounded	Verify black ground wire from module wire harness is grounded to metal chassis of appliance.

IntelliFire™ Ignition System (Continued)

Pilot sparks, but will not light.	Gas supply.	Verify that incoming gas line ball valve is “open”. Verify that inlet pressure reading is within acceptable limits.
	Ignitor gap is too large.	Verify gap of igniter to right side of pilot hood. The gap should be approximately .17 in. or 1/8 in. (3 mm).
	Module is not grounded.	Verify module is securely grounded to metal chassis of appliance.
	Pilot valve solenoid	Verify that 1.5 to 1.8 VDC is supplied to pilot solenoid from module. If below 1.5 volts, replace module. If 1.5 volts or greater, replace valve.
Pilot lights but continues to spark, and burner will not ignite. (If the pilot continues to spark after the pilot flame has been lit, flame rectification has not occurred.)	A short or loose connection in flame sensing rod.	Verify all connections to wiring diagram in manual. Verify connections underneath pilot assembly are tight. Verify connections are not grounding out to metal chassis, pilot burner, pilot enclosure or screen if present, or any other metal object.
	Poor flame rectification or contaminated flame sensing rod.	Verify correct pilot orifice is installed and gas inlet is set to pressure specifications. Check pilot for soot. Clean if necessary.
	Module is not grounded.	Verify module is securely grounded to metal chassis of appliance. Verify that wire harness is firmly connected to the module.
	Damaged pilot assembly or contaminated flame sensing rod	Verify that ceramic insulator around the flame sensing rod is not cracked, damaged, or loose. Verify connection from flame sensing rod to white sensor wire. Polish flame sensing rod with fine steel wool to remove any contaminants that may have accumulated on flame sensing rod. Verify continuity with a multimeter with ohms set at lowest range. Replace pilot if any damage is detected.
	Module	Turn wall control to OFF position. Remove ignitor wire “I” from module. Turn wall control to ON position. If there is no spark at “I” terminal module must be replaced. If there is a spark at “I” terminal, module is fine.

C. Troubleshooting – Screen/LEDs/Control Panel

SYMPTOM	POSSIBLE CAUSE	CORRECTIVE ACTION
LED Lights will not turn on (Appliance or Control Panel)	No AC power to appliance	Check that GFCI breaker is operating as intended and is not tripped. Verify that AC power has been connected to the appliance. Ensure that both the 3V IPI control module power supply as well as the LED power supply are securely plugged into the appliance junction box.
	Faulty Wiring	Check appliance for loose/corroded connections or shorted wires.
	LED Failure	Check for 12VDC from power supply. If 12VDC is present, LED strip is bad.
	Power Supply Failure	Check for 12VDC. If no 12VDC is present, power supply is bad
	Control Panel Failure	Replace Switch assembly
Appliance does not turn on when Control Panel on/off switch is depressed	No AC power to appliance	Check that GFCI breaker is operating as intended and is not tripped. Verify that AC power has been connected to the appliance. Ensure that both the 3V IPI control module power supply as well as the 12V screen and LED power supply are securely plugged into the appliance junction box.
	Faulty Wiring	Check appliance for loose/corroded connections or shorted wires.
	Control Panel Failure	Replace Control Panel

D. Accessing the LEDs

1. Turn off gas supply and disconnect main power to appliance before performing any maintenance.
2. Remove glass deflection shield and place on a clean flat surface.
3. Remove all media from hearth surface.
4. Remove screen to access LED strips inside LED channels.
5. To access LED control module and power module, lift engine and place two legs provided under engine against lower front space at the bottom of the face, attaching at the top in slots suspending engine giving open access to all controls.

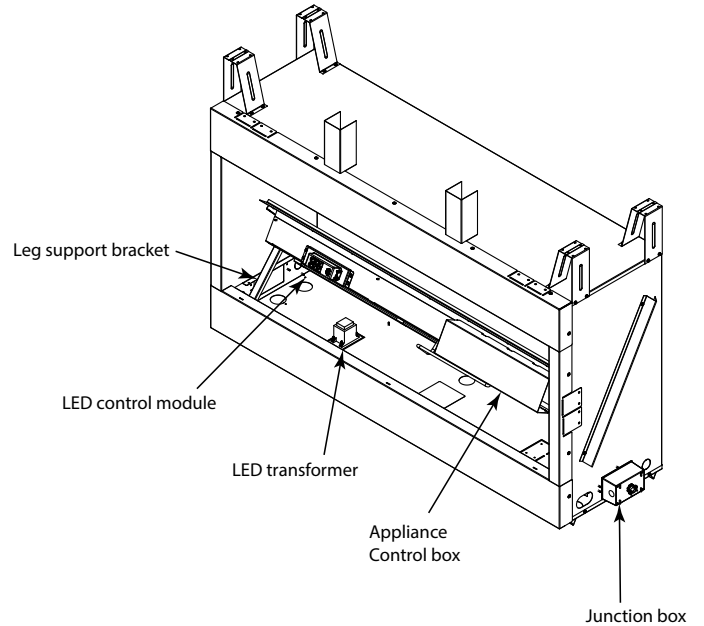

Figure 5.1. Appliance with engine lifted

6 Reference Materials

A. Accessories

Optional Media Kits

Several optional glass media kits are available for the Lanai series outdoor gas appliance. Contact your dealer for more information.

Media Kits:

- Media-Ebony-48
- Media-Cobbalt-48
- Media-Red-48
- Media-Amber-48

Optional Screen – ODLANAIG-51SCN

- The Lanai series outdoor gas appliance offers a screen that is designed to protect the inside of the appliance from trash and other debris (sticks, leave, etc.) This appliance may be operated with the screen installed.

Optional Trim Kit – ODLANAIG-51CFT

- The Lanai series outdoor gas appliance offers a trim kit that will allow the owner the option to cover the face of the appliance down to the firebox opening. This four (4) piece kit comes with an integrated eyebrow and 3/4" stainless steel lip that frames in the opening for a clean and seamless install.

CAUTION! Risk of Fire and Electric Shock! Use ONLY Hearth & Home Technologies-approved optional accessories with this appliance. Using non-listed accessories could result in a safety hazard and will void warranty

B. Service Parts

Parts must be ordered from a dealer or distributor. Hearth and Home Technologies does not sell directly to consumers. Provide model number and serial number when requesting service parts from your dealer or distributor.

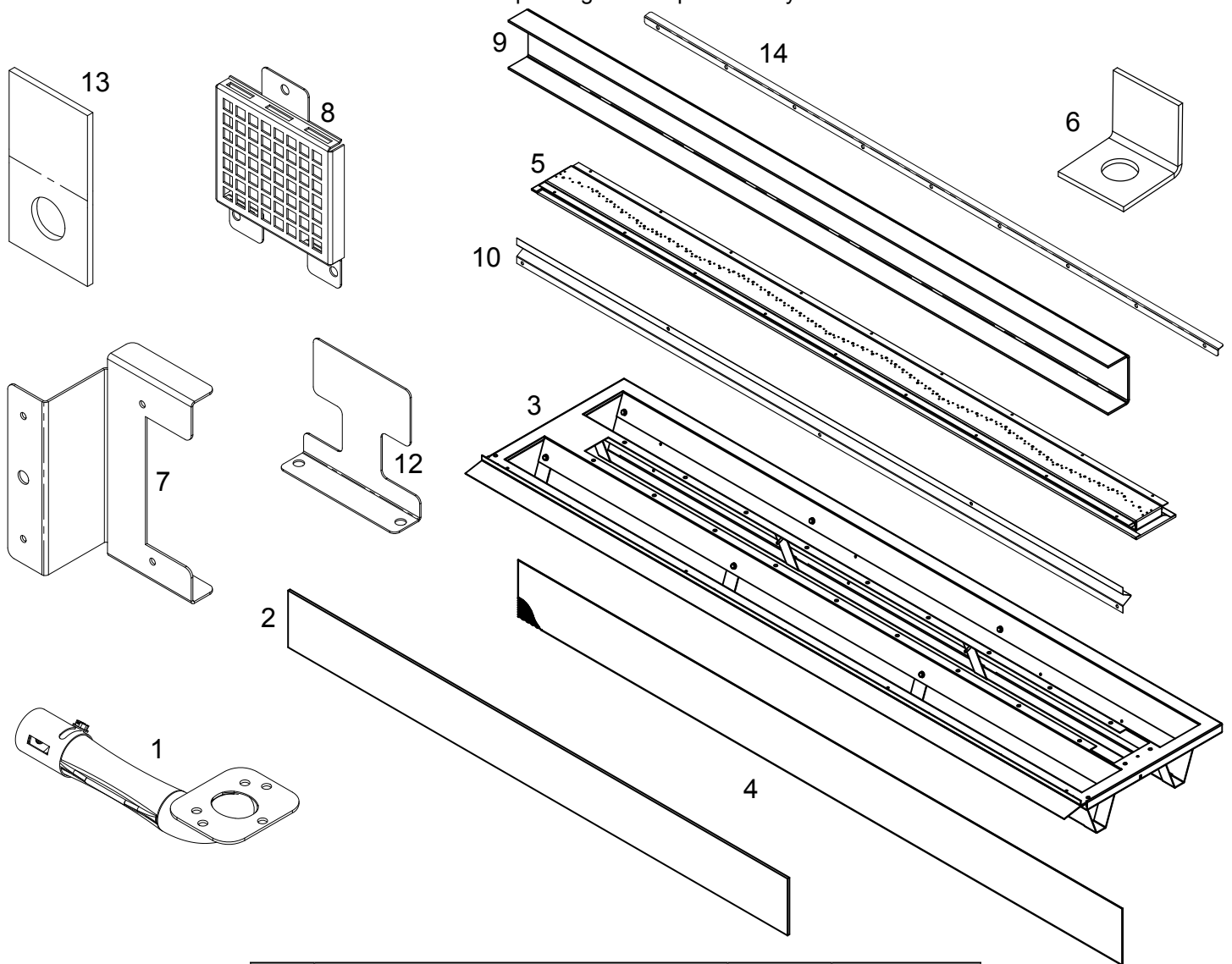

Item	Description	Quantity	Part Number
1	Venturi NG	1	20306795K
2	Deflection glass	1	20308474K
3	Engine base assembly	1	20308479K
4	Expanded metal SS	2	20308481K
5	Burner assembly	1	20308482K
6	Glass support bracket	4	20308486K
7	Pilot bracket	1	20308520K
8	Pilot shield	1	20308521K
9	Engine stand	2	20308575K
10	Bottom standoff	2	20308606K
*11	Glass Media (Box of 3 bags)	1	20308640K
12	Media placement jig	1	20308651K
13	Mesh screen retainer bracket	4	20308694K
14	Flame baffle	1	20308707K

* Item not shown

Parts must be ordered from a dealer or distributor. Hearth and Home Technologies does not sell directly to consumers. Provide model number and serial number when requesting service parts from your dealer or distributor.

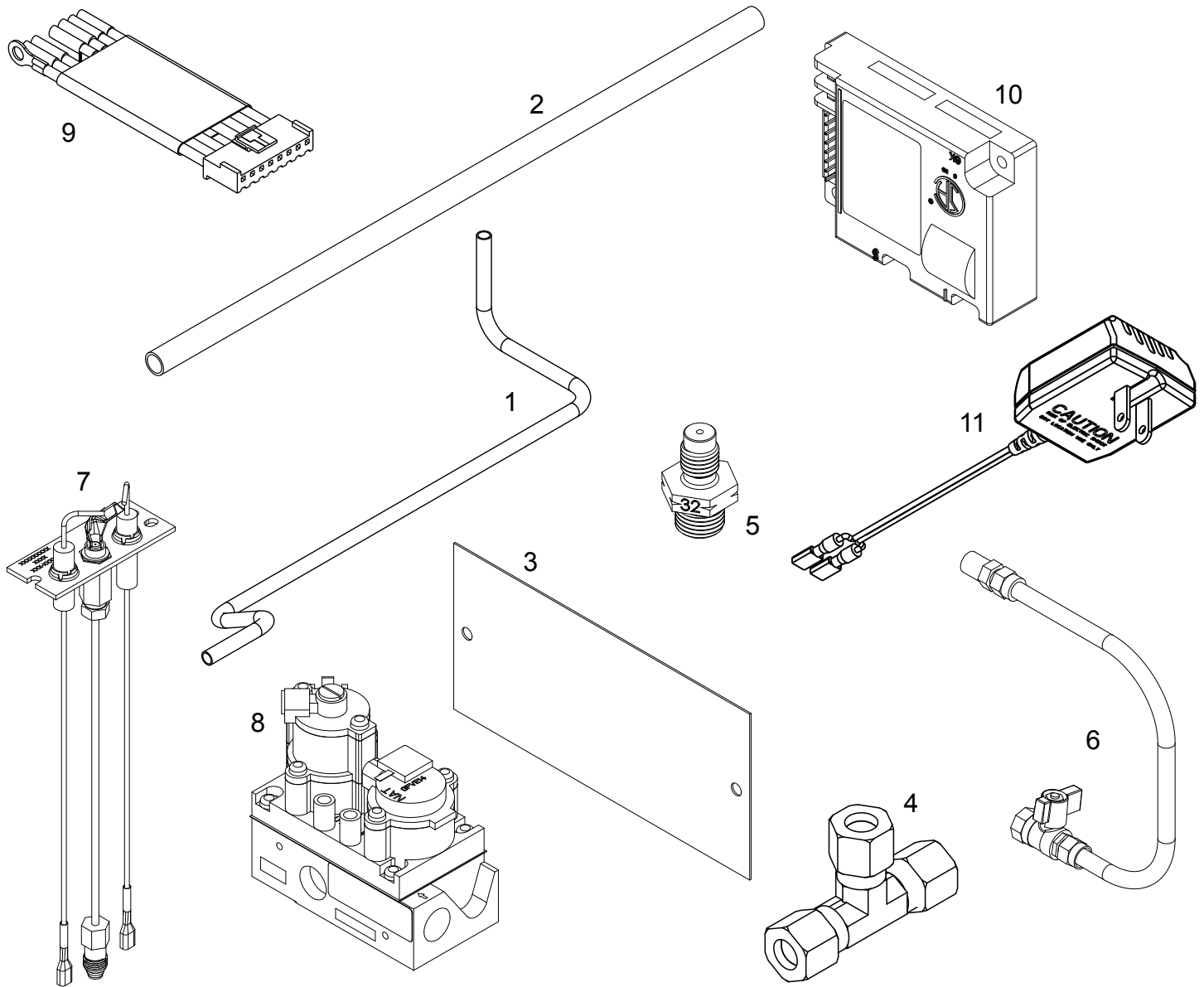

Item	Description	Quantity	Part Number
1	Valve to tee tube	1	20308554K
2	Tee to injector tube	2	20308556K
3	Cover plate	1	20308643K
4	Brass tee	1	43D0181K
5	Injector drill #32	2	57D0209K
6	Flexline, w/ shutoff valve	1	69D0030K
7	Pilot assembly, NG	1	2090-012
8	Gas valve assembly, NG, Fixed	1	593-500
9	Wire assembly	1	593-590A
10	Control module	1	593-592
11	3V Transformer	1	593-593A

Parts must be ordered from a dealer or distributor. Hearth and Home Technologies does not sell directly to consumers. Provide model number and serial number when requesting service parts from your dealer or distributor.

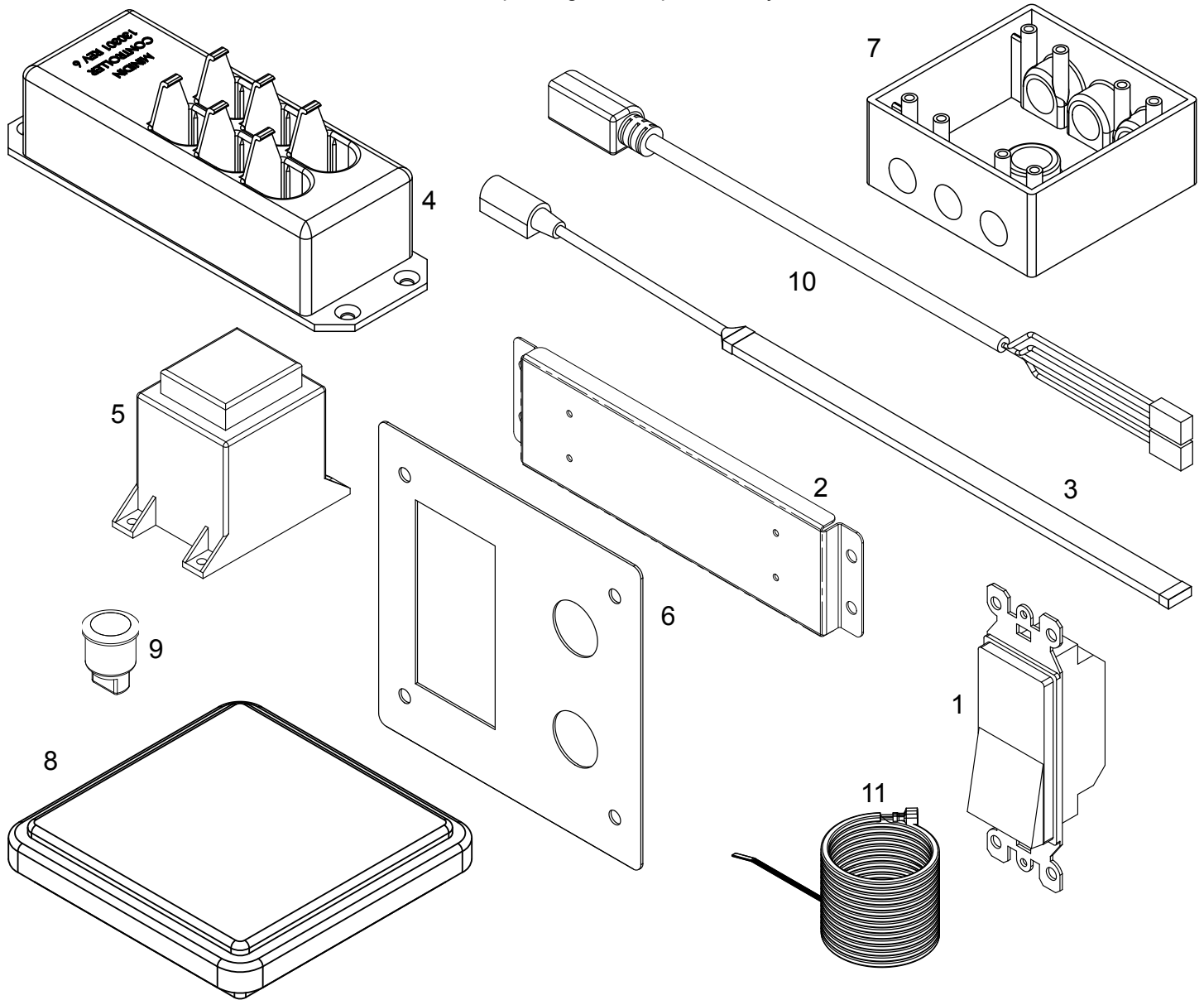

Item	Description	Quantity	Part Number
1	Rocker switch	1	20304686K
2	LED Control mounting plate	1	20308519K
3	LED Light strip	2	20308557K
4	LED Control module	1	20308558K
5	LED Power module	1	20308559K
6	4 x 4 Mounting plate	1	20308583K
7	Outdoor outlet box	1	20308584K
8	Receptacle cover	1	20308585K
9	LED Panel switch	2	20308586K
10	14' Aux input cable	1	20308587K
11	SCS Wall switch wire	1	20308590K

Parts must be ordered from a dealer or distributor. Hearth and Home Technologies does not sell directly to consumers. Provide model number and serial number when requesting service parts from your dealer or distributor.

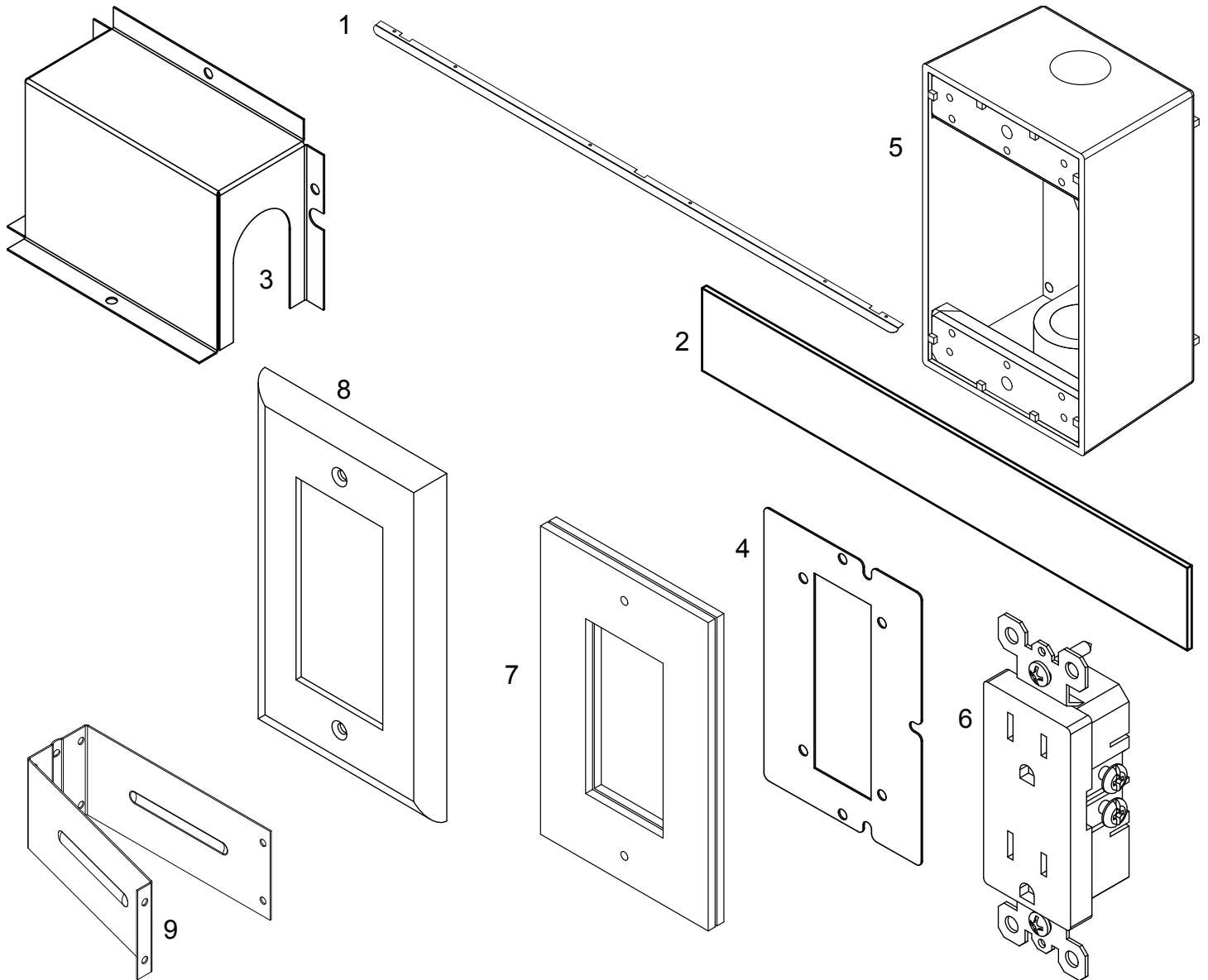

Item	Description	Quantity	Part Number
1	Eyebrow	1	20308497K
2	Non-combustible board	1	20308566K
3	A/C Outlet box cover	1	20308627K
4	A/C Box mounting plate	1	20308642K
5	Weatherproof outlet box	1	20308644K
6	Wall receptacle	1	20308645K
7	Rectangular gasket	2	20308646K
8	Wall plate	1	20308647K
9	Top standoff	4	78D1055K



C. Contact Information



Outdoor Lifestyles, a brand of Hearth & Home Technologies
 149 Cleveland Dr., Paris, KY 40361
www.hearthnhome.com

Please contact your Outdoor Lifestyles dealer with any questions or concerns.
 For the location of your nearest Outdoor Lifestyles dealer,
 please visit www.hearthnhome.com.

- NOTES -

NOTICE		
	Important operating and maintenance instructions included.	Read, understand and follow these instructions for safe installation and operation.
		 Leave this manual with party responsible for use and operation.

This product may be covered by one or more of the following patents: (United States) 5601073, 5613487, 5647340, 5890485, 5941237, 6006743, 6019099, 6053165, 6145502, 6374822, 6484712, 6601579, 6769426, 6863064, 7077122, 7098269, 7258116, 7470729, 8147240 or other U.S. and foreign patents pending.