

# Owner's Manual

## Care and Operation

**INSTALLER:** Leave this manual with party responsible for use and operation.

**OWNER:** Retain this manual for future reference.

Contact your local dealer with questions on installation, operation or service.

**NOTICE: SAVE THESE INSTRUCTIONS**

# HARMAN®

**BUILT TO A STANDARD, NOT A PRICE**

**Model(s):**

**Absolute63 Freestanding Pellet Stove**



Absolute63  
Use & Care Video



We suggest that our  
hearth products be  
installed and serviced by  
professionals who are  
certified in the U.S. by  
the National Fire Protection  
Association (NFPA) as well  
as local authorities.

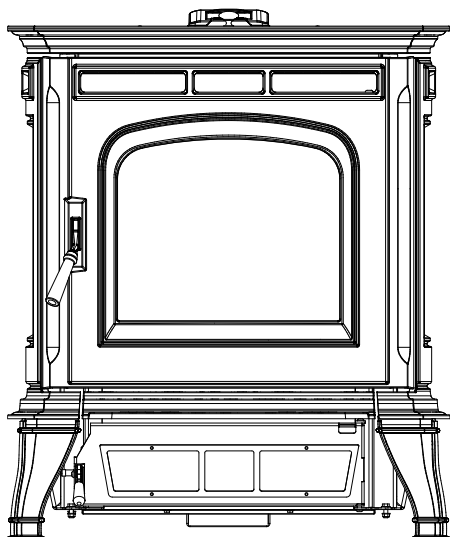

Tested &  
Listed By **UL** E-Listed  
c US  
OMNI-Test Laboratories, Inc. Portland  
Oregon USA



### CAUTION

Tested and approved for wood pellet fuel only. Burning of any other type of fuel voids your warranty.



### CAUTION

Check building codes prior to installation.

- Installation **MUST** comply with local, regional, state and national codes and regulations.
- Contact local building or fire officials about restrictions and installation inspection requirements in your area.



### WARNING



Please read this entire manual before installation and use of this pellet fuel-burning room heater.

Failure to follow these instructions could result in property damage, bodily injury or even death.

- Do not store or use gasoline or other flammable vapors and liquids in the vicinity of this or any other appliance.
- Do not overfire - If any external part starts to glow, you are overfiring. Reduce feed rate. Overfiring will void your warranty.
- Comply with all minimum clearances to combustibles as specified. Failure to comply may cause house fire.



### WARNING



### HOT SURFACES!

Glass and other surfaces are hot during operation AND cool down.

**Hot glass will cause burns.**

- Do not touch glass until it is cooled.
  - **NEVER** allow children to touch glass.
  - Keep children away.
  - **CAREFULLY SUPERVISE** children in same room as stove.
  - Alert children and adults to hazards of high temperatures.
- High temperatures may ignite clothing or other flammable materials.**
- Keep clothing, furniture, draperies and other flammable materials away.

### NOTE

To obtain a French translation of this manual, please contact your dealer or visit [www.harmanstoves.com](http://www.harmanstoves.com).

Pour obtenir une traduction française de ce manuel, s'il vous plaît contacter votre revendeur ou visitez [www.harmanstoves.com](http://www.harmanstoves.com)

**Read this manual before operating this appliance.  
Please retain this Owner's Manual for future reference.  
Read the Installation Manual before making any installation or finishing changes.**

**Congratulations,** The Harman® Absolute63 pellet stove you have selected is designed to provide the utmost in safety, reliability, and efficiency.

As the owner of a new pellet stove, you'll want to read and carefully follow all of the instructions contained in this owner's manual. Pay special attention to all cautions and warnings.

This owner's manual should be retained for future reference. We suggest that you keep it with your other important documents and product manuals.

Your new Harman® Absolute63 Freestanding Pellet Stove will give you years of durable use and trouble-free enjoyment. Welcome to the Harman® family!

**Listing Label Information/Location** The model information regarding your specific stove can be found on the rating plate usually located in the control area of the stove.

Model Name
Serial Number

**Report #/Rapport #** 0135PS036S & 0135PS036E

**Test listé/à:** ASTM E 2779-10, ASTM E 2515-11, ASTM E 1509-12, UL-C-9827-00, EPA Method 28R

**Test date:** March 2016

**Room Heater, Pellet Fuel-Burning Type, Also For Use in Mobile Homes. (UM) 94-HUD**

**"PREVENT HOUSE FIRES"** Install and use only in accordance with manufacturer's installation and operation instructions. Contact local building or fire officials about restrictions and installation inspection in your area.

**WARNING: FOR MANUFACTURED HOMES:** Do not install appliance in a sleeping room. An outside combustion air inlet must be provided. The structural integrity of the manufactured home floor, ceiling and walls must be maintained.

Refer to manufacturer's instructions and local codes for precautions required for passing chimney through a combustible wall or ceiling. Inspect and clean exhaust venting system frequently in accordance with manufacturer's instructions.

Use a 3" or 4" diameter type "L" or "PL" venting system.

Do not connect this unit to a chimney flue servicing another appliance.

Do not obstruct the space beneath the heater.

**FOR USE WITH PELLETIZED WOOD FUEL ONLY.**

EPA Certified Emissions: 1.4 g/hr  
Input Rating Max: 7.6 lb. fuel/hr  
**Electrical Rating:** 240 VAC, 50 Hz, Start 1.75 AMPS, Run 1.25 AMPS  
**U.S. Electrical Rating:** 115 VAC, 60 Hz, Start 3.5 AMPS, Run 2.5 AMPS  
Fuel Type: Wood Pellet Only

Route power cord away from unit.  
**OPERATE ONLY WITH DOORS CLOSED**  
**DANGER:** Risk of electrical shock. Disconnect power supply before servicing.  
Replace glass only with 5mm ceramic available from your dealer.  
For further instruction refer to owner's manual.  
Keep viewing and ash removal doors tightly closed during operation.

**Modèle: ABSOLUTE63**  
Room Heater, Pellet Fuel-Burning Type  
SUITABLE FOR MOBILE-HOME INSTALLATION

This pellet burning appliance has been tested and listed for use in Manufactured Homes in accordance with CAN 814-23-900 through 814-23-909

**MINIMUM CLEARANCES TO COMBUSTIBLES**

Back Wall to Appliance 2"  
Side Wall to Appliance 6"  
Corner Installation Walls to Appliance 6.25"

Use a non-combustible floor protector extending under and to the sides, front and back of the unit as shown in floor protection diagram. Measure front distance from the surface of the glass door.

**Recommended: Non-combustible floor protection extended beneath the flue pipe when installed with horizontal venting.**

**Floor Protection\***

	USA	CANADA
Sides (A)	6"	152 mm
Back (B)	1"	25 mm
Front (C)	6"	152 mm

**Alcove Installation**

Min. Alcove Height 48" (1219mm)  
Max. Alcove Depth 36" (914mm)

**PAROIE À L'APPAREIL**  
Appareil de chauffage à granulés de bois  
CONÇU POUR MAISON MOBILIÈRE

Test pour / testé à la norme ASTM E 2779-10, ASTM E 2515-11, ASTM E 1509-12, UL-C-9827-00, EPA Method 28R

Date du test / de la norme: Mars 2016

Appareil: Chauffage à granulés de bois, utilisable pour les maisons mobiles (UM) 94-HUD

**"PRÉVENIR LES INCENDIES"** Installer et utiliser uniquement conformément aux instructions d'installation et d'utilisation de l'appareil. Contacter les autorités locales de bâtiment ou de pompiers pour connaître les restrictions et les inspections dans votre région.

**ATTENTION: POUR MAISONS PRÉFABRIQUÉES:** Ne pas installer l'appareil dans une salle de repos. Une entrée d'air de combustion à l'extérieur doit être fournie. L'intégrité de la structure du plancher de la maison, le plafond et les murs fabriqués doivent être maintenus.

Reportez-vous aux instructions du fabricant et les codes locaux pour connaître les précautions nécessaires pour faire passer la cheminée à travers un mur ou un plafond combustible. Inspectez et nettoyez système d'évacuation des gaz d'échappement souvent en conformité avec les instructions du fabricant.

Utilisez un type de diamètre "L" 3" ou 4" ou "PL" du système de ventilation.

Ne pas connecter cet appareil à un conduit de cheminée servant un autre appareil.

Ne pas obstruer l'espace sous le chauffe-eau.

**POUR UTILISATION AVEC GRANULE DE BOIS.**

Entrée Puissance Max: E 7,3 combustible / h  
Puissance électrique: 240 V, 50 Hz, Lancer: 1,75 AMPS, Exécuter 1,25 AMPS

États-Unis électrique Note: 115 VAC, 60 Hz, Lancer 3,5 AMPS, Run 2,5 AMPS

Type de carburant: granulés de bois, 5 mm de diamètre.

**Route cordon électrique de l'appareil.**  
FAIRE FONCTIONNER UNIQUEMENT LORSQUE LES PORTES SONT FERMÉES

**DANGER:** Risque d'électrocution. Coupez l'alimentation électrique avant l'entretien.  
Remplacer le verre avec 5 mm miroir verre céramique de la même qualité disponible auprès de votre revendeur.

En tenant la porte d'entrée et le couvercle de la trémie hermétiquement fermé pendant le fonctionnement de l'appareil.

**DISTANCES DE SECURITE PAR RAPPORT AUX MATERIAUX COMBUSTIBLES**

	USA	CANADA
Paroi arrière à l'appareil	51 mm	152 mm
Paroi latérale de l'appareil	152 mm	152 mm
Installation en angle	Entre murs et appareil	159 mm
Installation en alcove	Hauteur minimale de l'alcove	1219 mm
	Profondeur maximale de l'alcove	914 mm

**PROTECTION DU SOL\***

	USA	CANADA
Côtés (A)	6"	152 mm
Arrière (B)	1"	25 mm
Avant (C)	6"	152 mm

Utiliser une protection de sol non combustible sous l'appareil qui s'étend sur les côtés, l'avant et l'arrière du poêle (voir schéma). Pour la distance à l'avant, mesurer à partir de la surface de la porte en verre. Il est recommandé que la protection s'étende jusque sous le conduit en cas d'installation d'un conduit horizontal ou sous le té en cas conduit vertical.

Do not remove this label/Ne pas enlever cette étiquette. Made in the USA/Fabriqué aux E.-U.

US ENVIRONMENTAL PROTECTION AGENCY  
Certified to comply with 2020 particulate emission standards.  
Certifié conforme aux normes 2020 d'émission de particules.

Date of Manufacture / Date de fabrication  
2016 2017 2018 JAN FEB MAR APR MAY JUN JUL AUG SEP OCT NOV DEC  
3-90-063 Manufactured by/Fabriqué par: Hearth and Home Technologies Rev C

# Table of Contents

## 1 Product Specifications and Important Safety Information

A. Appliance Certification / Specifications	4
B. Mobile Home Approval	4
C. BTU & Efficiency Specifications	4
D. Appliance Safety	5
E. Clear Space	5
F. Helpful Hints	6
G. Fuel Specifications	6
H. Quick Start Guide	8
I. Frequently Asked Questions	9
J. Cleaning Prompts, Messages and Errors	10

## 2 Maintenance and Service

A. Proper Shutdown Procedure	11
B. Quick Reference Maintenance Chart	11
C. Burnpot Maintenance	12
D. Combustion Fan Chamber	13
E. Glass Maintenance	13
F. Firebox	12

## ▲ Safety Alert Key:

- **DANGER!** Indicates a hazardous situation which, if not avoided **will** result in death or serious injury.
- **WARNING!** Indicates a hazardous situation which, if not avoided **could** result in death or serious injury.
- **CAUTION!** Indicates a hazardous situation which, if not avoided, could result in minor or moderate injury.
- **NOTICE:** Used to address practices not related to personal injury.

## 3 Reference Materials

A. Service Parts	14
B. Limited Lifetime Warranty	19
C. Loss of Power Addendum	21
D. Emergency Manual Ignition	21
E. Troubleshooting	22
F. Contact Information	24

➔ = Contains updated information

# 1 Product Specific and Important Safety Information

## A. Appliance Certification / Specifications

<b>MODEL:</b>	Absolute63 Pellet Stove
<b>LABORATORY:</b>	OMNI Test Laboratories, Inc
<b>REPORT NO.</b>	0135PS036S & 0135PS036E
<b>TYPE:</b>	Pellet Fueled/Supplementary For Residential Use
<b>STANDARD(s):</b>	ASTM E 2779-10, ASTM E 2515-11, ASTM E 1509-12, ULC-S627-00, EPA Method 28R
<b>ELECTRICAL RATING:</b>	115 VAC, 60 Hz, Start 3.5 AMPS, Run 2.5 AMPS
<b>GLASS SPECIFICATION:</b>	5mm mirrored ceramic glass

The Absolute63 is Certified to comply with 2020 particulate emission standards.



**NOTE:** This installation must conform with local codes. In the absence of local codes you must comply with the **ASTM E 1509-12, ULC-S627-00, (UM) 84-HUD**

## B. Mobile Home Approval

This appliance is approved for mobile and manufactured home installations when not installed in a sleeping room and when an outside combustion air inlet is provided.

The structural integrity of the mobile home floor, ceiling, and walls must be maintained. The appliance must be properly grounded to the frame of the mobile home and use only listed pellet vent, Class "PL" or "L" connector pipe.

A Harman® Outside Air Kit must be installed in a mobile home installation.

⚠	WARNING
THE STRUCTURAL INTEGRITY OF THE MANUFACTURED HOME FLOOR, WALL, AND CEILING/ROOF MUST BE MAINTAINED.	
DO NOT INSTALL IN SLEEPING ROOM.	

**NOTE:** Hearth & Home Technologies, manufacturer of this appliance, reserves the right to alter its products, their specifications and/or price without notice.

Harman® is a registered trademark of Hearth & Home Technologies.

## C. BTU & Efficiency Specifications

<b>EPA Certification Number:</b>	54-16
<b>EPA Certified Emissions:</b>	1.4 g/hr
<b>*LHV Tested Efficiency:</b>	83.2%
<b>**HHV Tested Efficiency:</b>	77.7%
<b>***EPA BTU Output:</b>	10,200 - 46,400
<b>****BTU Input</b>	14,100 - 61,800
<b>Vent Size:</b>	3 Inch
<b>Hopper Capacity:</b>	72 lbs
<b>Fuel:</b>	Wood Pellets

\* Weighted average LHV efficiency using data collected during EPA emissions test.

\*\*Weighted average HHV efficiency using data collected during EPA emissions test.

\*\*\*A range of BTU outputs based on EPA Default Efficiency and the burn rates from the low and high EPA tests.

\*\*\*\*Based on the maximum feed rate per hour multiplied by approximately 8600 BTU's which is the average BTU's from a pound of pellets.

This wood heater has a manufacturer-set minimum low burn rate that must not be altered. It is against federal regulations to alter this setting or otherwise operate this wood heater in a manner inconsistent with operating instructions in this manual.

This wood heater needs periodic inspection and repair for proper operation. It is against federal regulations to operate this wood heater in a manner inconsistent with operating instructions in this manual.

**Risk of Fire!** *Hearth & Home Technologies disclaims any responsibility for, and the warranty and agency listing will be voided by the below actions.*

### DO NOT:

- *Install or operate damaged appliance.*
- *Modify appliance.*
- *Install other than as instructed by Hearth & Home Technologies.*
- *Operate the appliance without fully assembling all components.*
- *Overfire.*
- *Install any component not approved by Hearth & Home Technologies.*
- *Install parts or components not Listed or approved.*
- *Disable safety switches.*

*Improper installation, adjustment, alteration, service or maintenance can cause injury or property damage.*

*For assistance or additional information, consult a qualified installer, service agency or your dealer.*

## D. Appliance Safety (Cont.)

### CAUTION

Odors and vapors released during initial operation

- Curing of high temperature paint
- Open windows for air circulation

Odors may be irritating to sensitive individuals.

### WARNING

If you expect that small children or vulnerable adults may come into contact with this appliance, the following precautions are recommended:

- Install a physical barrier such as:
  - A decorative fire screen.
  - Adjustable safety gate.
- Never leave children alone near a hot stove, whether operating or cooling down.
- Teach children to **NEVER** touch the stove.
- Consider not using the stove when children will be present.
- Use only specified components as replacement parts. Other components may not allow your stove to operate as it was intended.

Contact your dealer for more information, or visit: [www.hpba.org/safety-information](http://www.hpba.org/safety-information).

To prevent unintended operation when not using your stove for an extended period of time (summer months, vacations, trips, etc):

- Unplug stove from receptacle.

Due to high temperatures, this stove should be placed away from traffic, furniture and draperies.

Children and adults should be alerted to the hazards of high surface temperatures and should stay away to avoid burns to the skin and/or clothing.

Young children should be carefully supervised when they are in the same room as the stove.

Clothing and other flammable materials should not be placed on or near this stove.

Installation and repair of this stove should be done by a qualified service person. The appliance should be inspected before use and at least annually by a qualified service person. More frequent cleaning will be required. It is imperative that control compartments and circulating air passageways of this stove be kept clean.

### WARNING

**THIS WOOD HEATER HAS A MANUFACTURER-SET MINIMUM LOW BURN RATE THAT MUST NOT BE ALTERED. IT IS AGAINST FEDERAL REGULATIONS TO ALTER THIS SETTING OR OTHERWISE OPERATE THIS WOOD HEATER IN A MANNER INCONSISTENT WITH OPERATING INSTRUCTIONS IN THIS MANUAL.**

## E. Clear Space

### WARNING

**RISK OF FIRE! Do NOT place combustible objects in front or to the sides of the appliance. High temperatures may ignite clothing, furniture or draperies.**

**NOTICE:** Clearances may only be reduced by means approved by the regulatory authority having jurisdiction.

### WARNING

**RISK OF FIRE! Keep combustible materials, gasoline and other flammable vapors and liquids clear of appliance.**

- Do **NOT** store flammable materials in the appliance's vicinity.
- Do **NOT** use gasoline, lantern fuel, kerosene, charcoal lighter fluid or similar liquids to start or "freshen up" a fire in this heater.

*Keep all such liquids well away from the heater while it is in use as combustible materials may ignite.*

### WARNING

**MOBILE/MANUFACTURED HOME GUIDELINES: DO NOT ALLOW INSTALLATION IN A SLEEPING ROOM.**

### WARNING

**USE OF IMPROPER FUELS, FIRESTARTERS OR ALTERING THE STOVE FOR HIGHER HEAT OUTPUT MAY CAUSE DAMAGE TO THE STOVE AND COULD RESULT IN A HOUSE FIRE. USE ONLY APPROVED FUELS AND OPERATION GUIDELINES.**

### CAUTION

**THE STOVE IS HOT WHILE IN OPERATION. KEEP CHILDREN, CLOTHING AND FURNITURE AWAY. CONTACT MAY CAUSE SKIN BURNS.**

## F. Helpful Hints

When operating your Harman® Absolute63 Pellet Stove, follow basic safety standards. Read these instructions carefully before you attempt to operate the Absolute63 Pellet Stove. Failure to do so may result in damage to property or personal injury and may void the product warranty.

**Cleaning Burn Pot:** Whenever your stove is not burning, take the opportunity to scrape the burn pot to remove carbon buildup. A vacuum cleaner is handy to remove the residue. Be sure the stove is cold if you use a vacuum.

Carbon buildup can be scraped loose with the fire burning using the special tool provided with your stove. Scrape the floor and sides of the burn pot. The carbon will be pushed out by the incoming fuel. Always wear gloves when scraping the burnpot.

**Disposal of Ashes:** Ashes should be placed in a steel container with a tight fitting lid. The closed container of ashes should be placed on a non-combustible floor or on the ground, well away from all combustible materials, pending final disposal. If the ashes are disposed of by burial in soil or otherwise locally dispersed, they should be retained in the closed container until all cinders have thoroughly cooled. Other waste shall not be placed in this container.

**Soot and Flyash Formation and Need for Removal:** The products of combustion will contain small particles of flyash. The flyash will collect in the exhaust venting system and restrict the flow of the flue gases. Incomplete combustion, such as occurs during startup, shutdown, or incorrect operation of the room heater will lead to some soot formation which will collect in the exhaust venting system. The exhaust venting system should be inspected at least once every year to determine if cleaning is necessary.

When burning wood pellets on low, the potential exists for creosote to form. The venting system should be inspected periodically throughout the heating season to determine if creosote buildup has occurred. If a significant layer of creosote has accumulated (1/8" or more), it should be removed to reduce the risk of a chimney fire. If a fire occurs, call the fire department, shut down the stove, and evacuate the residence. Before using the appliance, have the venting system thoroughly inspected and replace any damaged components.

With any hearth appliance, installation of smoke detectors is recommended on every level of the home.

### **Possible causes of smoke detector activation:**

Paint curing process - Open a window near the appliance for the first few hours of burning.

Exhaust being drawn back inside the dwelling - Outside air connection to the appliance is necessary.

Vent leakage - All interior seams and joints should be sealed with silicone where applicable. Follow vent manufacturers instructions for proper sealing.



**CAUTION**

**This appliance must be vented to the outside**

## G. Fuel Specifications

The Absolute63 Pellet Stove is approved for burning any grade of pelletized bio-mass fuel.

It should be noted, that higher ash content fuel will require more frequent cleaning.

The moisture content of pellets must not exceed 8%. Higher moisture will rob BTU's and may not burn properly.

Fuel should **not** be stored within the stove installation clearances or within the space required for cleaning and ash removal.

### **Fuel and Fuel Storage**

Pellet fuel quality can fluctuate from manufacturer to manufacturer, and even from bag to bag.

Hearth & Home Technologies recommends using only fuel that is certified by the Pellet Fuels Institute (PFI).

#### Fuel Material

- Made from sawdust and/or other wood by-products.
- Source material typically determines ash content.

#### Higher Ash Content Material

- Hardwoods with high mineral content.
- Bark and leaves as source material.
- "Standard" grade pellets and other biomass.

#### Lower Ash Content Material

- Softwood; pine, fir, etc.
- Materials with lower mineral content.
- "Premium" grade pellets.

#### Performance

- Higher ash content requires more frequent maintenance.
- "Premium" grade pellets will produce the highest heat output.
- Burning pellets longer than 1-1/2 inches (38mm) can cause inconsistent feeding and/or ignition.

#### Clinkers

- Minerals and other non-combustible materials, like sand, will turn into a hard glass-like substance when heated.
- Trees from different areas will vary in mineral content. For this reason, some fuels will produce more clinkers than others.

#### Moisture

- Always burn dry fuel. Burning fuel with high moisture content takes energy to dry and tends to cool the appliance thus, robbing heat from your home.
- Damp pellet fuel could turn back into sawdust which does not flow properly through the feed system.

## G. Fuel Specifications (Cont.)

### Storage

- Wood pellets should be left in their original sealed bag until ready to use, to prevent moisture.
- Do not store fuel within the specified clearance areas, or in a location that will interfere with routine cleaning and maintenance procedures.

### NOTICE

Hearth & Home Technologies is not responsible for stove performance or extra maintenance required as a result of using fuel with higher ash or mineral content.

### CAUTION

***Do not burn fuel that contains an additive.***

- May cause hopper fire
- Damage to product may result

Read the list of ingredients on the packaging.

### CAUTION

Tested and approved for use with wood pellets ONLY. Burning of any other fuel will void your warranty.

### WARNING

**BURNING COLORED PAPER, CARDBOARD, SOLVENTS, TRASH AND GARBAGE OR ALTERING THE STOVE FOR HIGHER HEAT OUTPUT MAY CAUSE DAMAGE TO THE STOVE AND COULD RESULT IN A HOUSE FIRE. USE ONLY APPROVED FUELS AND FOLLOW ONLY THESE OPERATION GUIDELINES.**

### WARNING

**NEVER USE GASOLINE, GASOLINE-TYPE LANTERN FUEL, KEROSENE, CHARCOAL LIGHTER FLUID, OR SIMILAR LIQUIDS TO START OR 'FRESHEN UP' A FIRE IN THIS HEATER. KEEP ALL SUCH LIQUIDS WELL AWAY FROM THE HEATER, WHILE IN USE.**

### WARNING

*Tested and approved for use with wood pellets ONLY. Burning of any other fuel will void your warranty.*

## H. Quick Start Guide

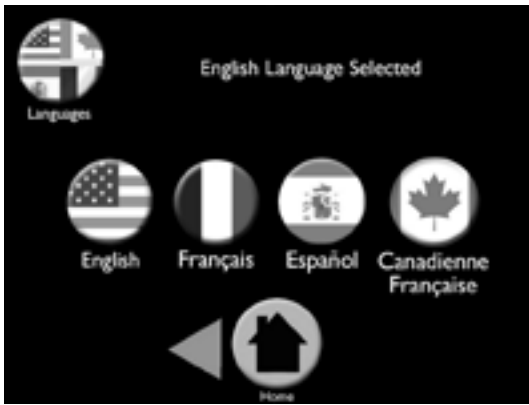

### Initial start-up Only

1. Select Language



2. Fill hopper with pellets

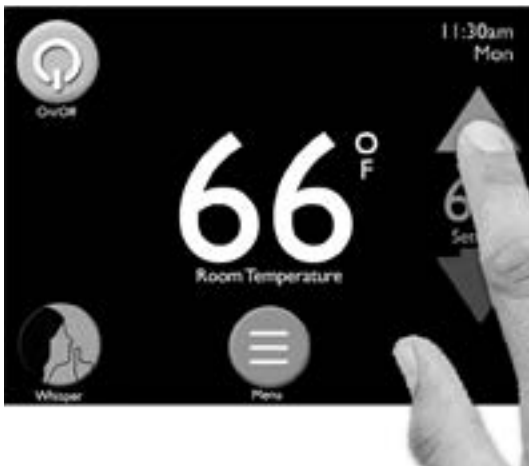

3. Adjust arrows to set room desired temperature.



4. Touch the On/Off Power Icon.

*Refer to Touch Manual for all other operations.*



## I. Frequently Asked Questions

With proper installation, operation, and maintenance your appliance will provide years of trouble-free service. If you do experience a problem, this troubleshooting guide will assist in the diagnosis of a problem and the corrective action to be taken.

**Contact your dealer for additional information regarding operation and troubleshooting. Visit [www.harmanstoves.com](http://www.harmanstoves.com) to find a dealer.**

ISSUES	SOLUTIONS
Metallic noise.	Noise is caused by metal expanding and contracting as it heats up and cools down, similar to the sound produced by a furnace or heating duct. This noise does not affect the operation or longevity of your appliance.
White ash buildup on glass.	This is normal. Clean the glass using any non-abrasive glass cleaner.
Glass has buildup of black soot.	Excessive build-up of ash. The lower burn settings will produce more ash, the higher burn settings produce less. The more it burns on low the more frequent cleaning of the glass is required.
Glass has turned dirty.	Excessive build up of ash. The lower burn settings will produce more ash, the higher burn settings produce less. The more it burns on low the more frequent cleaning of the glass is required.
Fire has tall flames with black tails and is lazy.	The feed rate needs to be reduced or the burnpot needs cleaning. Heat exchanger or exhaust blower needs cleaning.
Smoky start-up or puffs of smoke from the airwash.	Burnpot may be dirty, clean the burnpot.
Large flame at start-up.	This is normal. Flame will settle down once the fire is established.
Missed Ignition.	Ensure there are pellets in burnpot. Ensure holes in burnpot are clear of obstructions above the igniter. See Burnpot Maintenance. Check to see if the ignitor is getting hot, if not replace ignitor. *See manual ignition instructions for emergency heating needs.

## Touch Up Paint







The touch up paint provided with your unit is for fixing minor chips or blemishes that may occur after stove installation.

Unfortunately, because the finish of your stove is baked on, this touch up paint may not be a perfect match to the color of the original finish.

**To use this touch up paint:** Ensure the stove is cool and that the surface to be painted is clean. Apply in several light coats and take care to only coat the chipped area. Allow the paint to dry for 24 hours before touching or firing the stove.

## J. Cleaning Prompts, Messages and Errors



Your EASY Touch Control communicates with you by showing messages on the top center of the EASY Touch Control home screen. If you have more than one message, the messages will show consecutively until you acknowledge the message by performing the task. These communications include:

<b>PROMPTS</b>	Scrape Burn Pot and Reset Here 	When prompted, scrape burnpot. Press check-mark to reset.
	Empty Ash Pan and Press Here 	When prompted, inspect and empty ash pan as needed. Press check-mark to reset.
	Total Clean and Reset 	When prompted, inspect and perform total clean. Press check-mark to reset.
<b>MESSAGES</b>	Touch Here If Hopper Was Filled 	Press check-mark if you filled the hopper. If you did not fill hopper, The message will disappear in 30 seconds.
	Wireless Sensor Low Battery Warning	Replace the 2 "AA" batteries in the Wireless Remote Sensor.
	Using Backup Sensor	If Wireless Remote Sensor batteries die, the Back Up Sensor will continue to heat your home.
<b>ERRORS</b>	Warning: Door Open	Check and close the front and ash doors for the stove to continue to heat.
	Warning: Hopper Lid Open	Close the hopper lid for the stove to continue to heat.
	Error: Check Fuel and Reset 	Fill the hopper with pellets. Press check-mark to reset. If you did not fill the hopper, the message will stop after 30 seconds. This error only appears if "Show Fuel Gauges" is turned on.
	Wireless Signal Lost Replace Batteries in Wireless Sensor	Batteries in Wireless Remote Sensor have expired. Replace the 2 "AA" batteries.
	Return Air Sensor Failure	Return Air Sensor has failed. Call your Harman Dealer.
	Ignition Failure Correct and Reset 	Unit has failed to ignite. Scrape the burnpot. Call your Harman Dealer if problem persists.
	Connection Failure Control <====> Display	Touch Control has lost communication to the stove. Turn Stove off, allow stove to cool. Unplug stove and plug back in. If issue persist call your Harman Dealer.
	Exhaust Sensing Probe Failure	Exhaust Sensing Probe (ESP) as failed. Clean the ESP. If issue persists, call your Harman Dealer.
	Combustion Error Correct and Reset 	Clean your stove. Call your Harman Dealer if problem persists.

## 2 Maintenance & Service

When properly maintained, your stove will give you many years of trouble-free service. **Contact your dealer** to answer questions regarding proper operation, trouble-shooting and service for your appliance. Visit [www.harmanstoves.com](http://www.harmanstoves.com) to find a dealer. We recommend annual service by a qualified service technician.

### A. Proper Shutdown Procedure

 <b>CAUTION</b>	
	<p><b>Shock and Smoke Hazard</b></p> <ul style="list-style-type: none"> <li>• Turn unit to the off position, let appliance completely cool and combustion fan must be off. Now you can unplug appliance before servicing.</li> <li>• Smoke spillage into room can occur if appliance is not cool before unplugging.</li> <li>• Risk of shock if appliance not unplugged before servicing appliance.</li> </ul>

**NOTICE**

The type of fuel you are burning will dictate how often you have to clean your burnpot. Clean more frequently if you encounter heavy build-up of ash at the recommended interval or you see soot coming from the vent. **Not properly cleaning your appliance on a regular basis will void your warranty.**

Follow the detailed instructions found in this section for each step listed in the chart below.

### B. Quick Reference Maintenance Chart

Cleaning or Inspection	Frequency		Daily	Weekly	Monthly	Yearly
Ash Pan	Every 5 bags of fuel depending on the fuel type or ash build-up	OR		X		
Ash Removal from Firebox	Every 5 bags or more frequently depending on the fuel type or ash build-up	OR		X		
Heat Exchanger	Every 1 ton of fuel	OR			X	
Fan, Combustion (Exhaust)	More frequently depending on the fuel type	OR				X
Fan, Distribution	Every 25 bags or more frequently depending on the fuel type	OR			X	
Door Gasket Inspection	Prior to heating season	OR				X
Exhaust Path	More frequently depending on ash build-up	OR				X
Firebox - Prepare for Non-Burn Season	At end of heating season	OR				X
Burnpot - Burning pellets - hardwood	Every 3 bags	OR	X			
Burnpot - Burning pellets - softwood	Every 5 bags	OR	X			
Glass	When clear view of burnpot becomes obscure	OR		X		
Hopper / Hopper Lid Gasket	Every 50 bags of fuel or when changing fuel types	OR			X	
Venting System	More frequently depending on the fuel type	OR				X

## C. Burnpot Maintenance

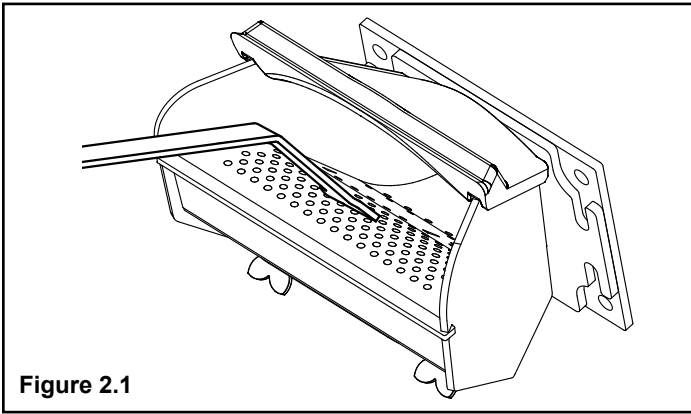
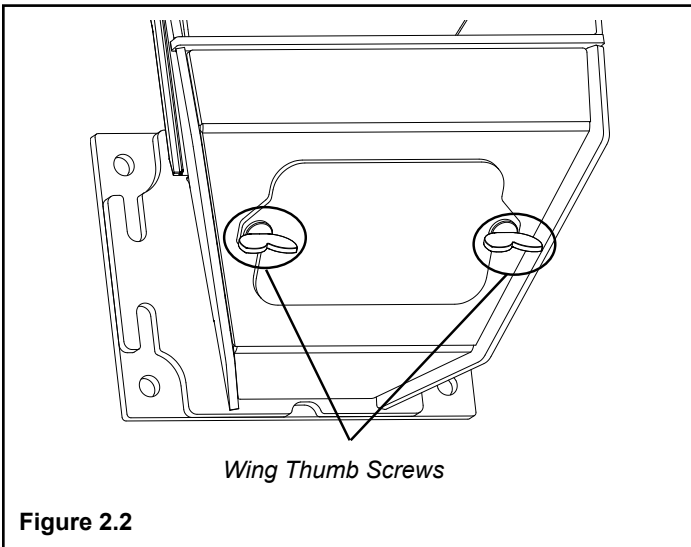

Figure 2.1



Wing Thumb Screws

Figure 2.2

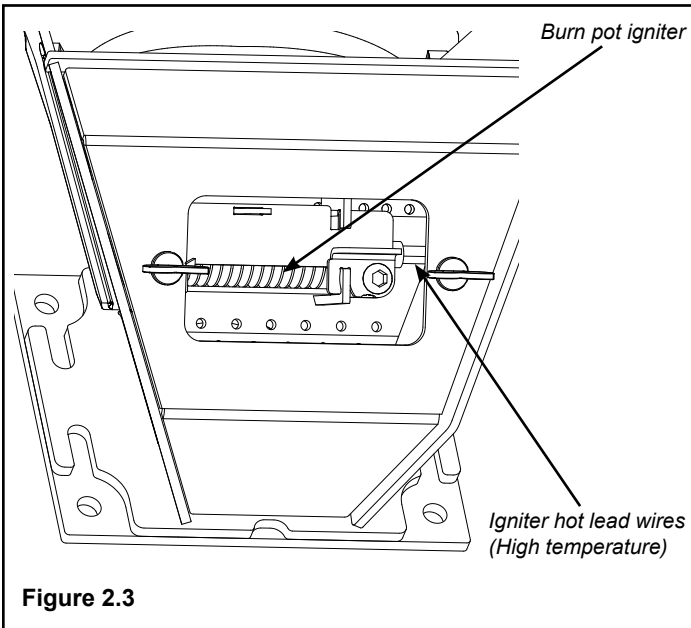

Figure 2.3

Viewed from below through the ash pan opening.

Whenever adding fuel, take the opportunity to clean the burn pot. **(Weekly at minimum)**

- Scrape the top grate and sides of the burn pot down to auger tube Figure 2.1. It is not necessary to completely remove all material from the burn pot. The excess will be pushed out during the next use.
- With the fire out and burn pot cold, use the supplied allen wrench to remove any build-up that may have accumulated in the holes of the burn pot grate. Simply push the allen wrench down through each hole ensuring it is clear of any build-up paying attention not to damage the igniter element in the process.

**Monthly, or after each ton of fuel burned:**

- Loosen the (2) wing thumb screws on the lower front angle of the burn pot. Figure 2.2
- Lift off the clean-out cover to open the bottom clean-out chamber. Figure 2.3

**⚠ DANGER**

**Disconnect the power to the unit before removing cover.**

- Clean ash buildup from inside the chamber while cover is off. Use the scraper tool and tap on the top front edge of the burn pot. This will help knock loose ash and other debris down through the burnpot. Prior to reinstalling the clean-out cover, ensure the igniter and bracket is clear of any ash build-up. Build-up can be removed using a vacuum.

### Figure 2.3

The igniter is made to be removable for service by insulated male/female wire connectors. These connections between the hot leads (the wires inside the burn pot) and the cold leads (the wires from the control board) are always pulled to the inside rear of the feeder body. **(Not coiled inside the burn pot.)**

It is very important that these connections are to the inside rear of the feeder body. Also, the extra wire of the igniter wire service loop must be pulled out through the rear of the feeder and tied up so that it will not be damaged by any moving parts.

**⚠ WARNING**

**When cleaning burn pot clean-out chamber. Do not damage the high temperature igniter wires.**

**Note: The hot lead/cold lead connection must always be pulled to the rear of the feeder body before operation.**

## D. Combustion Fan Chamber

### Monthly Cleaning- continued:

The combustion inlet cover is located behind the ash pan. The ash pan must be removed to properly clean the combustion fan blade. Figure 2.4.

- Remove the combustion inlet cover by pulling up on cover. This allows access to the combustion fan blade and exhaust path. Figure 2.4.
- Remove any flyash or debris that has collected around combustion fan blade with the provided paint brush.
- Clean exhaust passage.

**NOTE: The ESP Sensor is located just inside the exhaust passage. Be sure not to damage the ESP Sensor while cleaning the exhaust passage.**

- Once cleaned replace combustion inlet cover and ashpan.

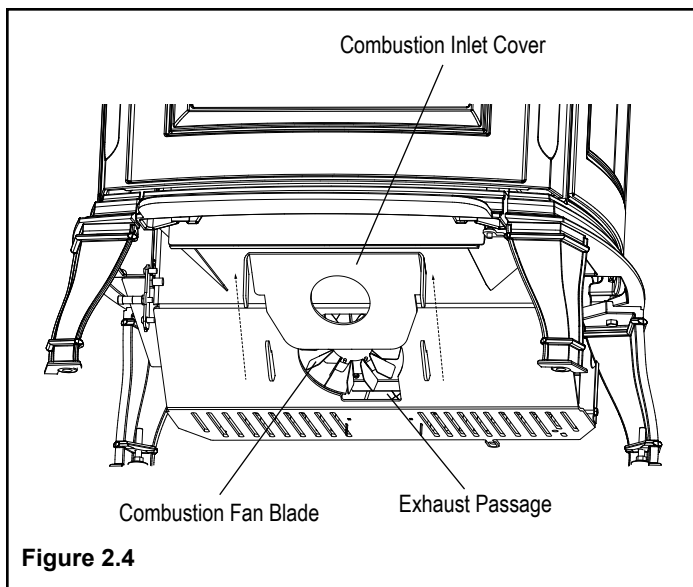

Figure 2.4

## E. Glass Maintenance

The glass used in your stove is manufactured to exact standards to withstand the high heat of the fire, but like all glass, it must be treated with common sense and care. Never abuse the glass by slamming the door shut or striking the glass with a heavy object. If the glass is broken or damaged, do not operate the stove until it has been replaced.

### Glass - Cleaning

It will be necessary to clean accumulated ash from the glass surface; allowing this ash to remain on the glass for long periods can result in "etching" due to the acidity of the ash. Never clean the glass while it is hot, and **do not** use abrasive substances. Wash the surface with cool water, and rinse thoroughly. You may wish to use a non-abrasive cleaner specifically designed for use on stove glass. In any case, dry thoroughly before relighting your stove.

### Glass - Replacement

If the stove's glass is cracked or broken, you must replace it before operating your stove. Remove pieces carefully. Replace glass only with Harman® replacement glass; **do not use substitutes.**

### Glass - Replacement (Cont.)

Carefully remove damaged glass, gasket material, and hold down clips (set aside).

Install the self adhesive 1/4" gasket material around the front face of the glass. Set the glass panel and gasket gently onto the door. Install the hold down clips and tighten with bolts.

Be sure to keep firing and de-ashing doors closed and ensure all seals are maintained and are in good condition. Figure 2.5.

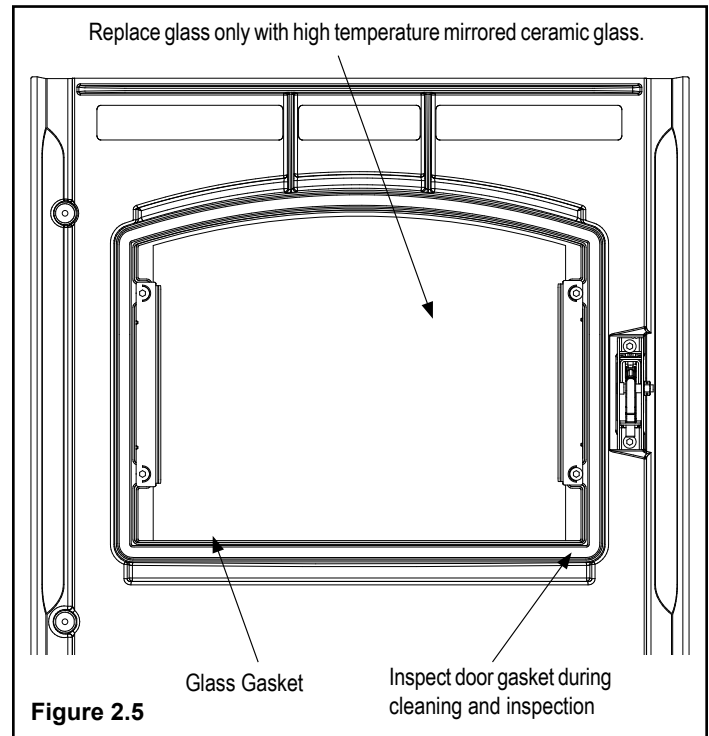

Figure 2.5

## F. Firebox

### Yearly Cleaning:

Remove flyash and carbon buildup from the smooth surfaces of the heat exchanger as well as other surfaces inside the firebox. Figure 2.6.

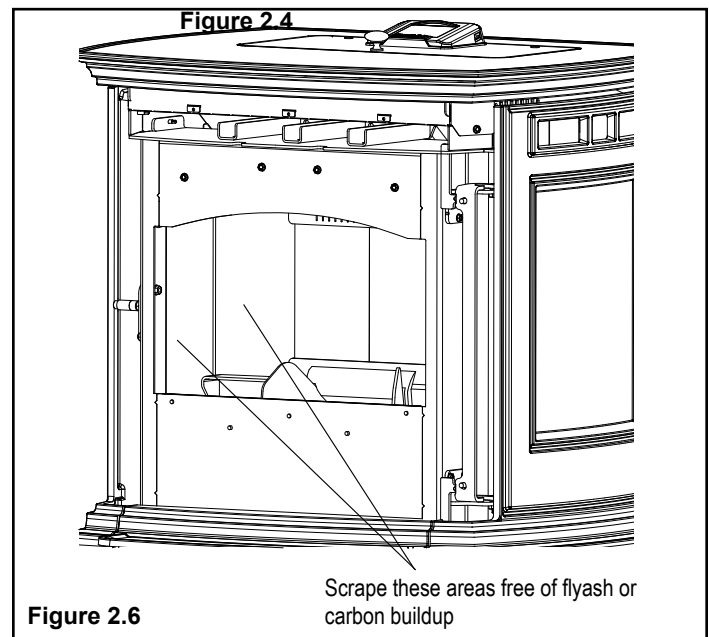

Figure 2.6

# 3 Reference Material

## A. Service Parts



### Service Parts

### Absolute 63

Pellet Stove  
1-90-999000-1 (Matte Black)  
1-90-999000-14 (Majolica Brown)

Beginning Manufacturing Date: Dec 2016  
Ending Manufacturing Date: Active

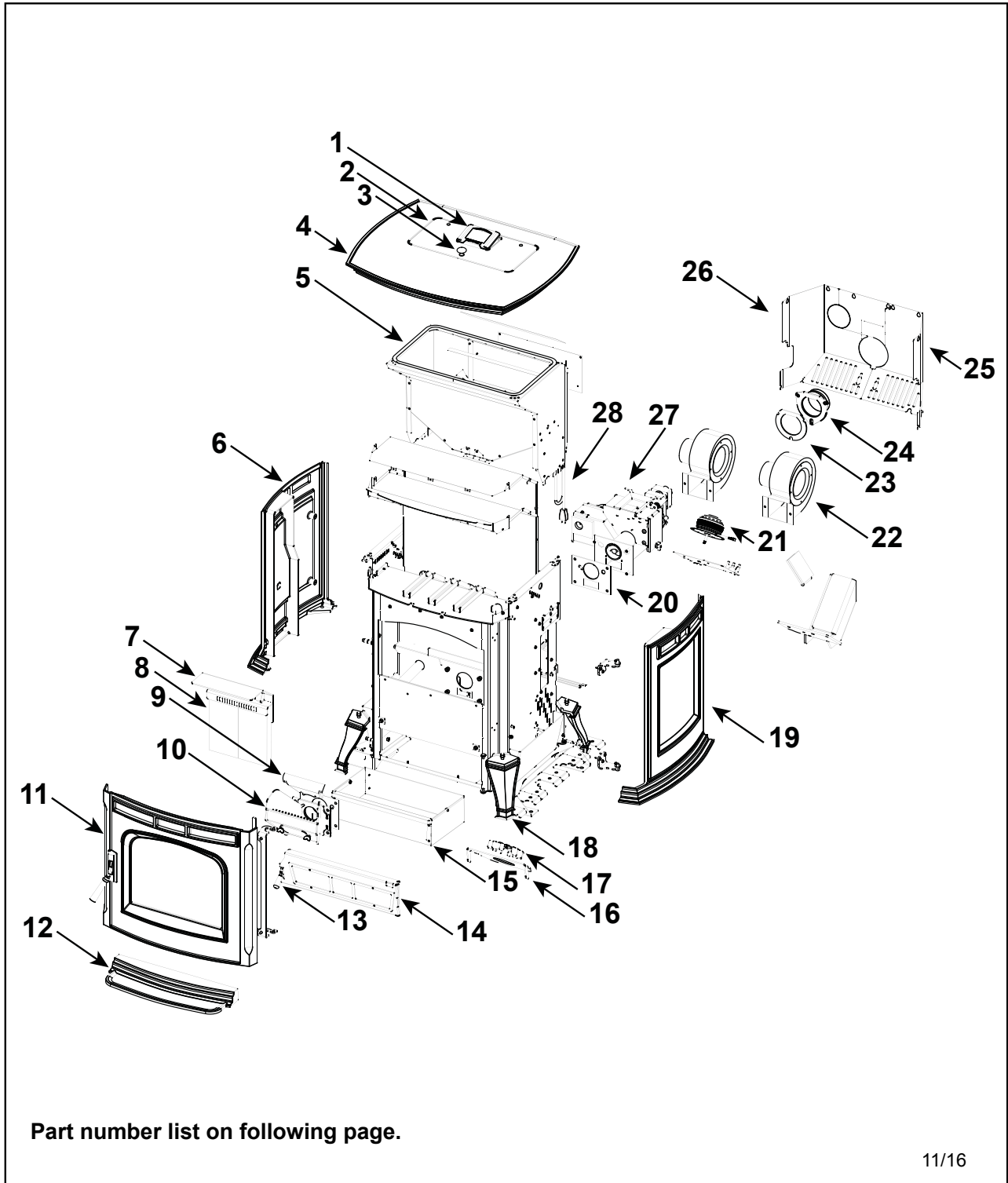

IMPORTANT: THIS IS DATED INFORMATION. Parts must be ordered from a dealer or distributor. **Hearth and Home Technologies does not sell directly to consumers.** Provide model number and serial number when requesting service parts from your dealer or distributor.



Stocked at Depot

ITEM	DESCRIPTION	COMMENTS	PART NUMBER	
1	Touch Control		1-00-777552	Y
2	16 X 8 Hopper Lid Glass		3-40-777770	Y
	Screwposts/Washers	Pkg of 20 Sets	1-00-129004	Y
	Gasket 3/8 X 1/2	20 Feet	1-00-375501	Y
3	Black Plated Knob w/Screw		1-00-02000-1	
	Complete Latch		1-00-0669697	
	5/16 X 1/2 Ball Plunger	Pkg of 3	3-31-5500-3	
	Bulk 5/16 Push Retainer	Pkg of 100	3-31-94807-100	
	Hopper Lid Hinge w/Hardware		1-00-777771	Y
	Hopper Lid Hinge Pin Plates w/Hardware	1 Set	1-00-777560	
4	Cast Top	Black	4-00-999132S	
		Majolica Brown	1-00-999132-14	
5	Hopper Assembly		1-10-999157A	Y
	Gasket Hopper Throat		3-44-677185	Y
	Gasket 3/8 X 1/2	20 Feet	1-00-375501	Y
6	Left Side Cast	Black	4-00-999130P	
		Majolica Brown	1-00-999130-14	
7	Brick Support		1-10-999779W	Y
8	Brick 9 X 4.5 X 1.25	Pkg of 7	1-00-900450125	Y
9	Flame Guide		3-00-06644	Y

### #10 Burn Pot Assembly

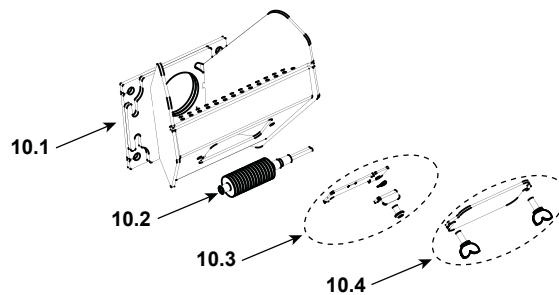

10	Burn Pot Assembly			
10.1	Burn Pot Weldment		1-10-999674W	Y
	Gasket, Burn Pot/Tailpipe	Pkg of 5	1-00-07381	Y
10.2	Igniter		3-20-677200	Y
		Pkg of 10	1-00-677200	Y
10.3	Igniter Cover w/Hardware		1-00-574402	Y
10.4	Cleanout Cover w/Hardware		1-00-06623	Y
	1/4"-20x5/8	Pkg of 10	3-31-782108-10	Y

Additional service parts on following page.

IMPORTANT: THIS IS DATED INFORMATION. Parts must be ordered from a dealer or distributor. **Hearth and Home Technologies does not sell directly to consumers.** Provide model number and serial number when requesting service parts from your dealer or distributor.



Stocked at Depot

ITEM	DESCRIPTION	COMMENTS	PART NUMBER	
<b>#11 Load Door</b>				
11	Load Door			
11.1	Cast Latch, Knob & Screw		1-00-0119	Y
	Wood Handle		3-40-00247	
11.2	Load Door Rope	Black	4-00-999144P	Y
		Majolica Brown	1-00-999144-14	Y
11.3	Latch Bracket w/Hardware	1 Set	1-00-777665	Y
11.4	Gasket 1/4 RD PSA	15 Feet	1-00-2312	Y
11.5	Glass w/Gasket		1-00-999146	Y
11.6	Glass Clips w/Hardware	1 Set	1-00-999145	Y
11.7	Load Door Hinge w/Hardware	1 Set	1-00-999114	Y
11.8	Gasket 3/8 4 Strand	30 Feet	1-00-00888	Y
12	Ashlip	Black	3-00-999129P	
		Majolica Brown	1-00-999129-14	
13	Ash Door Handle Assembly	1 Set	1-00-777149	Y
	Rollers & Hardware	1 Set	1-00-77723	Y
14	Ash Door, Complete		1-10-999135A	
	Gasket 3/8 4 Strand	30 Feet	1-00-00888	Y
15	Ash Pan		1-10-999133A	Y
16	Inlet Cover		1-00-777607	
17	Combustion Blower Fan Blade		1-10-574500A	Y
18	Leg w/Hardware	Black	1-00-249100	Y
		Majolica Brown	1-00-249100-14	Y
	Leg Leveling Kit	1 Set	1-00-12302	
19	Right Side Cast	Black	4-00-999131P	
		Majolica Brown	1-00-999131-14	
20	Gasket, Burn Pot / Tailpipe	Pkg of 5	1-00-07381	Y

Additional service parts on following page.



IMPORTANT: THIS IS DATED INFORMATION. Parts must be ordered from a dealer or distributor. **Hearth and Home Technologies does not sell directly to consumers.** Provide model number and serial number when requesting service parts from your dealer or distributor.



Stocked at Depot

ITEM	DESCRIPTION	COMMENTS	PART NUMBER	
21	Combustion Blower		1-00-02275	Y
	Combustion Blower Capacitor		3-20-00276	Y
	Studs and Nuts	5 Sets	1-00-99922	
22	Distribution Blower	Qty 2 req	3-21-33647	Y
23	Gasket, Burn Pot / Tailpipe	Pkg of 5	1-00-07381	Y
24	Pellet Tailpipe, Cast		3-00-247237	Y
25	Rear Cover, Right		1-00-999125	Y
26	Rear Cover, Left		1-00-999126	Y

### #27 Feeder Assembly

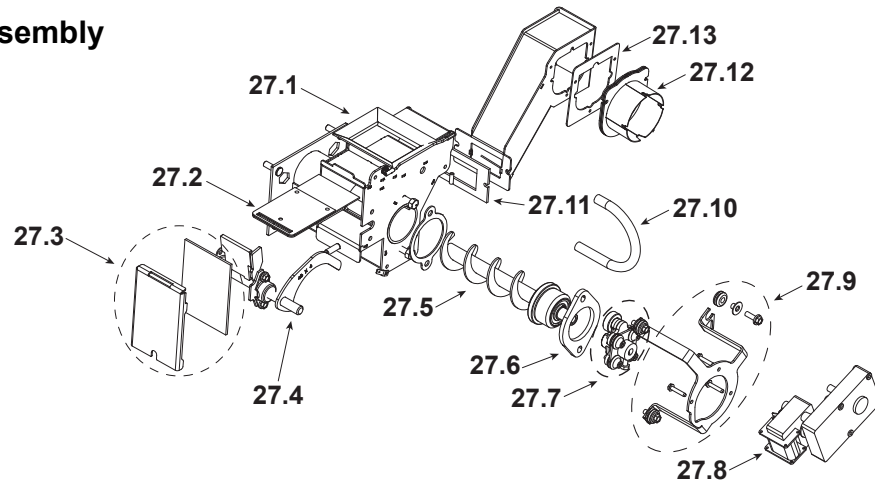

27	Feeder Assembly			
27.1	Feeder Body		1-10-680021W	Y
27.3	Slide Plate Assembly		1-10-677121A	Y
27.3	Feed Cover & Gasket	2 Sets	1-00-677122	Y
27.4	Pusher Arm		1-10-677131W	Y
	Pillow Block	Pkg of 4	3-31-3614087-4	Y
27.5	Auger		3-50-00565	Y
27.6	Bearing Retainer w/Hardware		1-00-04035	Y
	Cam Bearing		3-31-3014	Y
27.7	Cam Block Assembly		1-10-777620A	Y
27.8	4 RPM CW Outboard Motor, 120V		3-20-00999	Y
27.9	Motor Mount w/Hardware		1-00-999111	Y
27.10	Feeder Crossover Tube Kit		1-00-67900	Y
27.11	Gasket, Snout	Pkg of 10	3-44-677160-10	Y
27.12	Air Intake		1-10-06810A	
27.13	Gasket, Air Intake	Pkg of 6	3-44-72224-6	Y
28	Power Cord		3-20-51578	Y

Additional service parts on following page.



## B. Limited Lifetime Warranty

### Hearth & Home Technologies LIMITED LIFETIME WARRANTY

Hearth & Home Technologies, on behalf of its hearth brands ("HHT"), extends the following warranty for HHT gas, wood, pellet, coal and electric hearth appliances that are purchased from an HHT authorized dealer.

#### **WARRANTY COVERAGE:**

HHT warrants to the original owner of the HHT appliance at the site of installation, and to any transferee taking ownership of the appliance at the site of installation within two years following the date of original purchase, that the HHT appliance will be free from defects in materials and workmanship at the time of manufacture. After installation, if covered components manufactured by HHT are found to be defective in materials or workmanship during the applicable warranty period, HHT will, at its option, repair or replace the covered components. HHT, at its own discretion, may fully discharge all of its obligations under such warranties by replacing the product itself or refunding the verified purchase price of the product itself. The maximum amount recoverable under this warranty is limited to the purchase price of the product. This warranty is subject to conditions, exclusions and limitations as described below.

#### **WARRANTY PERIOD:**

Warranty coverage begins on the date of original purchase. In the case of new home construction, warranty coverage begins on the date of first occupancy of the dwelling or six months after the sale of the product by an independent, authorized HHT dealer/ distributor, whichever occurs earlier. The warranty shall commence no later than 24 months following the date of product shipment from HHT, regardless of the installation or occupancy date. The warranty period for parts and labor for covered components is produced in the following table.

The term "Limited Lifetime" in the table below is defined as: 20 years from the beginning date of warranty coverage for gas appliances, and 10 years from the beginning date of warranty coverage for wood, pellet, and coal appliances. These time periods reflect the minimum expected useful lives of the designated components under normal operating conditions.

Warranty Period		HHT Manufactured Appliances and Venting							Components Covered
Parts	Labor	Gas	Wood	Pellet	EPA Wood	Coal	Electric	Venting	
1 Year		X	X	X	X	X	X	X	All parts and material except as covered by Conditions, Exclusions, and Limitations listed
2 years				X	X	X			Igniters, electronic components, and glass
		X	X	X	X	X			Factory-installed blowers
			X						Molded refractory panels
3 years				X					Firepots and burnpots
5 years	1 year			X	X				Castings and baffles
7 years	3 years		X	X	X				Manifold tubes, HHT chimney and termination
10 years	1 year	X							Burners, logs and refractory
Limited Lifetime	3 years	X	X	X	X	X			Firebox and heat exchanger
90 Days		X	X	X	X	X	X	X	All replacement parts beyond warranty period

See conditions, exclusions, and limitations on next page.

## **B. Limited Lifetime Warranty (*continued*)**

### **WARRANTY CONDITIONS:**

- This warranty only covers HHT appliances that are purchased through an HHT authorized dealer or distributor. A list of HHT authorized dealers is available on the HHT branded websites.
- This warranty is only valid while the HHT appliance remains at the site of original installation.
- This warranty is only valid in the country in which the HHT authorized dealer or distributor that sold the appliance resides.
- Contact your installing dealer for warranty service. If the installing dealer is unable to provide necessary parts, contact the nearest HHT authorized dealer or supplier. Additional service fees may apply if you are seeking warranty service from a dealer other than the dealer from whom you originally purchased the product.
- Check with your dealer in advance for any costs to you when arranging a warranty call. Travel and shipping charges for parts are not covered by this warranty.

### **WARRANTY EXCLUSIONS:**

This warranty does not cover the following:

- Changes in surface finishes as a result of normal use. As a heating appliance, some changes in color of interior and exterior surface finishes may occur. This is not a flaw and is not covered under warranty.
- Damage to printed, plated, or enameled surfaces caused by fingerprints, accidents, misuse, scratches, melted items, or other external sources and residues left on the plated surfaces from the use of abrasive cleaners or polishes.
- Repair or replacement of parts that are subject to normal wear and tear during the warranty period. These parts include: paint, wood, pellet and coal gaskets, firebricks, grates, flame guides, batteries and the discoloration of glass.
- Minor expansion, contraction, or movement of certain parts causing noise. These conditions are normal and complaints related to this noise are not covered by this warranty.
- Damages resulting from: (1) failure to install, operate, or maintain the appliance in accordance with the installation instructions, operating instructions, and listing agent identification label furnished with the appliance; (2) failure to install the appliance in accordance with local building codes; (3) shipping or improper handling; (4) improper operation, abuse, misuse, continued operation with damaged, corroded or failed components, accident, or improperly/incorrectly performed repairs; (5) environmental conditions, inadequate ventilation, negative pressure, or drafting caused by tightly sealed constructions, insufficient make-up air supply, or handling devices such as exhaust fans or forced air furnaces or other such causes; (6) use of fuels other than those specified in the operating instructions; (7) installation or use of components not supplied with the appliance or any other components not expressly authorized and approved by HHT; (8) modification of the appliance not expressly authorized and approved by HHT in writing; and/or (9) interruptions or fluctuations of electrical power supply to the appliance.
- Non-HHT venting components, hearth components or other accessories used in conjunction with the appliance.
- Any part of a pre-existing fireplace system in which an insert or a decorative gas appliance is installed.
- HHT's obligation under this warranty does not extend to the appliance's capability to heat the desired space. Information is provided to assist the consumer and the dealer in selecting the proper appliance for the application. Consideration must be given to appliance location and configuration, environmental conditions, insulation and air tightness of the structure.

### **This warranty is void if:**

- The appliance has been over-fired or operated in atmospheres contaminated by chlorine, fluorine, or other damaging chemicals. Over-firing can be identified by, but not limited to, warped plates or tubes, rust colored cast iron, bubbling, cracking and discoloration of steel or enamel finishes.
- The appliance is subjected to prolonged periods of dampness or condensation.
- There is any damage to the appliance or other components due to water or weather damage which is the result of, but not limited to, improper chimney or venting installation.

### **LIMITATIONS OF LIABILITY:**

- The owner's exclusive remedy and HHT's sole obligation under this warranty, under any other warranty, express or implied, or in contract, tort or otherwise, shall be limited to replacement, repair, or refund, as specified above. In no event will HHT be liable for any incidental or consequential damages caused by defects in the appliance. Some states do not allow exclusions or limitation of incidental or consequential damages, so these limitations may not apply to you. This warranty gives you specific rights; you may also have other rights, which vary from state to state. EXCEPT TO THE EXTENT PROVIDED BY LAW, HHT MAKES NO EXPRESS WARRANTIES OTHER THAN THE WARRANTY SPECIFIED HEREIN. THE DURATION OF ANY IMPLIED WARRANTY IS LIMITED TO DURATION OF THE EXPRESSED WARRANTY SPECIFIED ABOVE.

## C. Loss of Power

### Minimizing Smoke During Loss of Power Using Battery Back-up

Harman® strongly recommends installing battery back-up to minimize entry of smoke into the room in the event of power loss.

Your pellet/biomass burning appliance relies on a combustion blower to remove exhaust. A power failure will cause the combustion blower to stop. This may lead to exhaust seeping into the room. Vertical rise in the venting may provide natural draft. It is, however, no guarantee against leakage.

There are two Harman® approved battery back-up options for your appliance:

**Uninterruptible Power Supply (UPS)** battery back-ups are available online or at computer and office equipment stores. Your Harman® appliance may be plugged directly into a Harman® approved UPS:

- The APC (American Power Conversion) model #BE750G and the TrippLite model INTERNET750U are tested and approved. Other brands or models may not be compatible.

When power is lost, a fully charged UPS will power a safe, combustion blower only shut-down. Your appliance will pulse the blower every few seconds to clear exhaust until the fire is out. **NOTE: The UPS provides safe shut-down only. It is not intended for continued operation.**

- The Surefire 512 connects to a 12 volt deep cycle battery that will run your appliance for up to eight (8) hours. It includes a trickle charge feature that keeps your battery charged when power is available. NOTE: If the power is out for longer than battery life, smoke leakage may still occur unless your stove has been safely shut down.

Your appliance will recognize when power is restored. What happens depends on ESP temperature and whether it is equipped with automatic ignition:

- In **“Automatic” Mode**, units will respond to the set point and ESP temperature and resume normal operation.
- In **“Idle” Mode**, or for units without automatic ignition:
  - If the ESP is cool, the appliance will remain shut down.
  - If the fire is out and the ESP is still warm, the feeder may restart. Since the fire is out, the ESP temperature will not rise. The unit will then shut-down, and may flash a six-blink status error. (See ESP error codes)
  - If the fire is still burning, it will resume normal operation.

Contact your dealer if you have questions about UPS compatibility with your appliance.

### WARNING

Use only Harman® approved battery back-up devices. Other products may not operate properly, can create unsafe conditions or damage your appliance.

### CAUTION

Always keep appliance doors and hopper lid closed and latched during operation and during power failures to minimize risk of smoke or burn-back.

## D. Emergency Manual Ignition

Harman® pellet stoves and inserts should be lit using the automatic ignition system. This is the safest and most reliable way for igniting the unit. In the event the automatic igniter is not functioning, the steps below may be followed to manually light the stove or insert in the “Constant Burn” mode. Manual lighting is for emergency purposes only, and the igniter should be repaired or replaced as soon as practical.

### WARNING

Only use firestarter commercially marketed for pellet stoves and inserts, including wax coated wood chips, pellet starter gel and pellet igniter blocks. Use of any other type of firestarter is prohibited.

To avoid serious injury or death read and follow manufacturer’s warning and instructions for use of firestarter. Use of firestarter is only permitted when performing a cold start.

Never attempt to manually light a stove or insert that has been operated recently and is not at room temperature. If automatic ignition was attempted, be sure to give the stove or insert at least 30 minutes or longer to cool to room temperature.

Be sure that the stove or insert is in the “Igniter - Disabled” mode of operation.

Once all the precautions have been taken, follow these steps:

1. On the touch control, select the Burn Mode icon then select “Constant Burn”.
2. Arrow back and select the Igniter icon then select “Manual” for the ignition method. Select the Home Icon to go back to the Main Menu.
3. Fill burn pot with pellets, only half way. (Do Not Over Fill).
4. Add firestarter to pellets following manufacturer’s instructions.
5. Light pellet firestarter with a match, and close the door, touch the On/Off icon on the home screen. Operation will begin when the fire reaches the proper temperature.

## E. Troubleshooting

ISSUES	SOLUTIONS
Stove does not feed	<ul style="list-style-type: none"> <li>• No fuel in hopper.</li> <li>• Firebox draft may be too low for sensing switch in feeder circuit to operate. <b>Check for closed doors</b>, loose or missing gasket on doors or hopper lid.</li> <li>• Restriction in the hopper or feeder. Remove all fuel and examine. Clear the obstruction.</li> <li>• Feed motor has failed.</li> </ul>
Partially burned pellets	<ul style="list-style-type: none"> <li>• Feed rate too high.</li> <li>• Poor air to fuel mixture. (Check burn pot clean-out cover and air intake).</li> <li>• Burn pot may need to be cleaned.</li> <li>• Combination of all the above.</li> </ul>
Smoke smell	Seal the vent pipe joints and connection to stove with silicone. The exhaust vent is the only part of the system that is under positive pressure.
Fire has gone out	<ul style="list-style-type: none"> <li>• No fuel in hopper.</li> <li>• Draft is too low, blocked flue.</li> <li>• Something is restricting fuel flow.</li> <li>• Hopper lid not closed properly.</li> <li>• Feed motor or combustion fan has failed.</li> </ul>
Smoke is visible coming out of vent	<ul style="list-style-type: none"> <li>• Air-fuel ratio is too rich.               <ul style="list-style-type: none"> <li>- Feed rate too high.</li> <li>- Draft too low caused by a gasket leak.</li> </ul> </li> </ul>
Low heat output	<ul style="list-style-type: none"> <li>• Feed rate too low.</li> <li>• Draft too low because of gasket leak.</li> <li>• Poor quality or damp pellets.</li> <li>• Combination of 1 and 2.</li> </ul>
Stove does not ignite but igniter is operating correctly	<ul style="list-style-type: none"> <li>• Burnpot has excess ash located around igniter and bracket.</li> <li>• Burpot grate holes are blocked or partially block.</li> </ul>



**F. Contact Information**

**HARMAN®**  
a brand of  
**Hearth & Home Technologies**  
352 Mountain House Road, Halifax, PA 17032  
www.harmanstoves.com

Please contact your Harman® dealer with any questions or concerns.  
For the location of your nearest Harman® dealer,  
please visit [www.harmanstoves.com](http://www.harmanstoves.com).

**- NOTES -**

---

---

---

---

---

---

---

---

---

---

---

**NOTICE**



**DO NOT DISCARD THIS MANUAL**

- Important operating and maintenance instructions included.
- Read, understand and follow these instructions for safe installation and operation.
- Leave this manual with party responsible for use and operation.



Printed in U.S.A.